

Operation Manual  
**Shut-off Valve Box**

VRF R32

in*s*ens

SVP-160A

in*s*ens

No. 0150582675

- Please read this manual carefully before using.
- Keep this operation manual for future reference.





Original instructions

# Contents

- 1.Warnings and Precautions ..... 2
- 2.Product Processing ..... 5
- 3.Environmental Protection ..... 5
- 4.About System ..... 6
- 5.Wired Remote Control ..... 7
- 6.Maintenance and Care ..... 8
  - 6.1.Preventive measures before any intervention ... 8
  - 6.2.In case of refrigerant leakage ..... 8
- 7.Troubleshooting ..... 9
- 8.Accessories ..... 9
- 9.Installation of the Equipment ..... 9
  - 9.1.Preparation for installation site ..... 9
  - 9.2.Selection for installation site ..... 9
- 10.Pipe Installation ..... 12
  - 10.1.Preparation of refrigerant pipe ..... 12
  - 10.2.Connection of refrigerant pipe ..... 12
- 11. Electrical Connection ..... 12
  - 11.1. Standard wiring specifications ..... 12
  - 11.2.Connecting wires to the indoor unit ..... 13
- 12.Debugging ..... 14
  - 12.1.Pre-debugging checklist ..... 14
  - 12.2.Error code for indoor unit..... 14
- 13.Equipment System Diagram..... 14

# 1 Warnings and safety precautions

Before carrying out any installation work, please read the warnings and precautions carefully.

	This symbol indicates that this appliance uses flammable refrigerant. There is a risk of fire if refrigerant leaks and is exposed to external fire sources.
	This symbol indicates that the equipment must be operated by qualified personnel in accordance with the installation instructions.
	Read the operating instructions carefully.
	Follow the recommendations provided in the installation instructions and the user operation manual.

## Installation and maintenance regulations

The installation and maintenance of the equipment must be carried out by authorised professionals in accordance with the regulations and technical rules in force, particularly in France:

- Legislation on the treatment of refrigerants: Decree No. 2007/737 and its implementing regulations.
- In accordance with articles R 543-75 to 123 of the Environmental Code and its implementing regulations, the repair of this air conditioner must be carried out by a qualified installer who holds a certificate of competence. As well as any other operation on the equipment requiring the handling of refrigerant fluids.
- NF C 15-100 and its amendments: Low voltage electrical equipment - Regulations.

## General rules

- Before carrying out any work, ensure that the general power supply is disconnected and recorded.
- The equipment is only suitable for use at altitudes of less than 2000 metres.
- Do not install or store near heat sources.
- Do not puncture or incinerate the equipment.
- The equipment does not contain any parts that can be repaired by the user. Leave it to the installation personnel.

- The appliance is not intended for use by children over the age of 8, or by persons with reduced physical, sensory or mental abilities, or lack of experience or knowledge, provided they are under suitable supervision or have received instructions on how to use the appliance safely and are aware of the risks involved. Children should not play with the equipment. Children should not clean or maintain the equipment without supervision.
- If the valve connections and their size, length, and thickness combinations specified in this manual are not followed, the operation of the equipment cannot be guaranteed.
- Do not come into contact with refrigerant during connection leaks or other operations. Direct contact can cause frostbite.
- Do not introduce substances other than recommended refrigerants into the unit.
- Do not touch refrigerant lines, water lines or internal components during or after operation. It may be too hot or too cold. Give it time to return to normal temperature. If you must touch it, wear protective gloves.
- Follow the safety and handling instructions for R32 refrigerant.
- When using R32 refrigerant, the unit should be stored in a room without stored in a room without a continuous source.

### Equipment transportation

- The outdoor unit must not be laid flat during transport. Horizontal transport can damage the unit due to refrigerant displacement and deformation of the compressor suspension. Damage caused by horizontal transport is not covered by the warranty. If necessary, the outdoor unit can only be tilted manually (through doors or stairs). Exercise caution when performing this operation and immediately return the unit to its vertical position.

### Refrigerant R32

- For additional loads, use tools and connections compatible with the liquid refrigerant specified on the unit nameplate.
- Do not release refrigerant to the atmosphere. If refrigerant leaks during installation, ventilation and air change should be carried out. After installation, there should be no refrigerant leaks in the circuit.
- This flammable and odourless liquid requires the minimum surface area and volume of the room in which the equipment is installed, stored or used. Ensure that the on-site application complies with the dimensions of the processed components and the fluid load of the equipment (in accordance with EN-378 standard).
- The taper pipe inside buildings shall not be reused. The flare joint on the pipe must be removed and a new flare joint must be manufactured.
- The tapered pipe inside buildings must not be reused. The flare on the pipe must be removed and a new flare made.
- The conical pipe outside buildings must not be reused.

### Refrigeration connection

- Do not use old, deformed or discoloured fittings, use new ones with good cooling properties.
- If used in an indoor ERP environment, dry nitrogen should be used to avoid introducing moisture harmful to the operation of the equipment.
- Do not use sealant on the refrigerant fitting as it may clog or contaminate the inside of the fitting. The use of sealant will void the warranty of the unit equipment warranty.
- All refrigeration circuits are subject to the of dust and moisture. If these contaminants enter the refrigeration circuit, they can cause a reduction in the unit's performance. It is necessary to ensure the correct sealing of the appliance connections and refrigeration circuits. In the event of a malfunction, the presence of moisture or foreign matter in the compressor oil will, according to expert opinion, systematically invalidate the warranty.
- The refrigerant connection must be kept sealed (by covering, clamping, folding, preferably brazing). Moisture seriously affects the normal operation and life of the product. In the event of contamination, it is difficult, if not impossible, to clean the circuit.
- Higher humidity may occur after storage or cooling. Please perform nitrogen flushing and vacuum pumping, taking into account the external temperature.
- Do not use normal mineral oil on the flare connection. Use refrigerant oil compatible with R32 and try to keep it out of the circuit as much as possible, otherwise it will reduce the life of the equipment.
- Do not use potential ignition sources to locate or detect refrigerant leaks.

## Installation

- These air conditioners are designed for residential and tertiary applications to ensure thermal comfort for users.
- They are not suitable for places with excessive humidity (such as distilleries, greenhouses, wine cellars, etc.), dusty air and strong electromagnetic interference (such as computer rooms, places near TV aerials or relays).
- The size of the unit must be appropriate to the requirements. It is recommended to consult an expert for thermal balance.
- Only qualified personnel should handle, charge, clean and dispose of refrigerant.
- The unit is not explosion proof and should not be installed in potentially explosive atmospheres.
- If the unit is to be moved, call the installation personnel to disassemble and reassemble the unit.
- Ensure that only the parts supplied or specified in the instruction manual are used during installation.
- Installers must follow the instructions in this manual when installing the equipment. Improper installation may result in serious damage, such as refrigerant or water leakage, electric shock or fire hazard. If the appliance is not installed in accordance with manual, the manufacturer's warranty will be invalid.
- Do not touch the fins of the heat exchanger as this may cause damage and injury.
- Take appropriate measures to prevent the unit from being used as a from being used as a shelter by small animals. Animals that come into contact with electrical may cause malfunction or fire. Inform the customer the customer that the area around the appliance must be must be kept clean.
- Install the unit in a location where it is easy to install gas, liquid and condensate drains.
- Install the air conditioner on a foundation that is strong enough to support the weight of the equipment. Insufficient foundation strength may cause the unit to fall and cause injury.
- Do not use suspended ceilings or other spaces as air intake or exhaust ducts.
- Install the indoor unit, outdoor unit, power cord, connection cable and remote control cable at least 1 metre away from the TV or radio receiver. This is a precautionary measure to avoid interference (however, even at a distance of 1 metre or more, the signal may still be affected by interference).
- Ensure that the electrical box cover and the service panel are properly secured. If the electrical cabinet cover or service panel of the product is not properly secured, there is a danger of fire and electric shock caused by dust, water, etc.

- To avoid electric shock, operate the product with dry hands.

## Electrical connection

- The rated operating voltage of this equipment is 230 volts AC 50 hertz. The voltage at the terminals of the unit must not be lower than 220 V AC or higher than 240 V AC at any time (including during start-up).
- The maximum length of the cable depends on the voltage drop, which must be less than 2%. If the voltage drop is greater than or equal to 2%, use a cable with a larger cross-section.
- Electrical connections can only be made after all the other installation operations (fixing assembly, etc.).
- Check whether the wiring is prone to wear, corrosion, excessive pressure, vibration, sharp edges, or any other adverse environmental effects.
- Check that the wiring is not subject to wear, corrosion, excessive pressure, vibration, sharp edges or other adverse environmental influences.
- These air conditioners are designed for the following neutral conditions: TT and TN. Neutral states are not applicable to these units (using isolation transformers). It is strictly forbidden to use single-phase power sources without neutral (between phases). For three-phase equipment, the neutral must also be uniformly distributed (TT or TN).
- The contract signed with the energy supplier must be sufficient to cover not only the power of the equipment, but also the sum of the power of all the equipment that may be used at the same time. If there is not enough power, check the power level specified in the contract with the power company.
- Check with the distribution network operator for cable specifications and harmonic currents.
- Do not use power sockets to supply power.
- If the power cord is damaged, it must be replaced by qualified personnel to avoid danger.
- Use a dedicated power circuit. Do not share power with other equipment.
- Do not install phase advance capacitors as the unit is equipped with an inverter. Phase advance capacitors will reduce performance and may cause accidents.
- Use an independent power cord protected by a full-pole circuit breaker with a contact opening greater than 3mm to supply power to the equipment.
- Electrical equipment must have 30 mA differential protection.
- Ensure that the circuit breaker is located in a place (outbuilding, etc.) where the user cannot accidentally start or stop it. If the switchboard is located outdoors, close and lock it so that it cannot be accessed.

- Do not open the main circuit breaker except in an emergency. Doing so will cause compressor failure and water leakage. Only use any type of remote control or external input device (switch) to switch off the indoor unit and then disconnect the circuit breaker.
- Wait 10 minutes after disconnecting the power supply before touching electrical components. Static electricity in the human body can damage components. Remove static electricity from your body. Do not touch electrical parts with wet hands. Electric shock may result.
- If there is any sign of malfunction (such as a burning smell), stop the installation immediately, turn off the circuit breaker, and consult qualified personnel.
- Ground the equipment. Incorrect grounding may result in electric shock.
- Incorrect wiring can damage the entire system.
- Use cable ties to secure cables and keep them away from sharp edges or pipes, especially on the high voltage side.
- Do not use taped cables, twisted cables, extension cables or star-shaped system connections. They may cause overheating, electric shock or fire.
- If the voltage is too low or anomalies occur during start-up of the equipment, it may be difficult to start the equipment. In such cases, please contact your power company.
- Ensure the safety of all cables, use cables that comply with current standards (in particular NF C 15-100) and ensure that the terminals and cables are not subjected to external forces.



Sharp element



Protective gloves



Protective glasses



Protective cuff

### 3 Environmental Protection



The symbol on the product or on the packaging indicates that this product must not be disposed of with your other household waste.

It must be handed over to the collection point responsible for the recycling of electrical and electronic equipment. Separate collection and recycling at the time of disposal helps to conserve natural resources and ensures safe recycling for the environment and human health. For more information on waste collection points, please contact your authorised service centre or your dealer. Do not attempt to disassemble the system: The disassembly of the system and the handling of refrigerant, oil and other components must be carried out by a qualified technician in accordance with local and national regulations. Waste equipment and batteries must be sent to specialised facilities for recycling or reuse.

#### These units shall comply with the following instructions:

- 2014/30/EU Electromagnetic Compatibility (EMC)
- 2006/42/EC Machinery Directive
- 2014/35/EU Low Voltage Directive
- 2014/68/EU Pressure Equipment Directive
- 2009/125/EC Ecodesign Directive
- 2011/65/EU ROHS

## 2 Product Processing

Use personal protective equipment (PPE) to handle products.

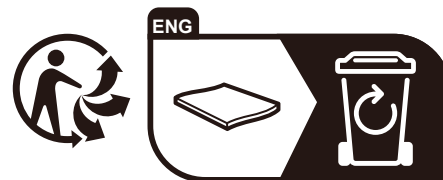

On the [www.quefairedemesdechets](http://www.quefairedemesdechets) website, the recycling sites will give priority to repairing or donating your equipment!

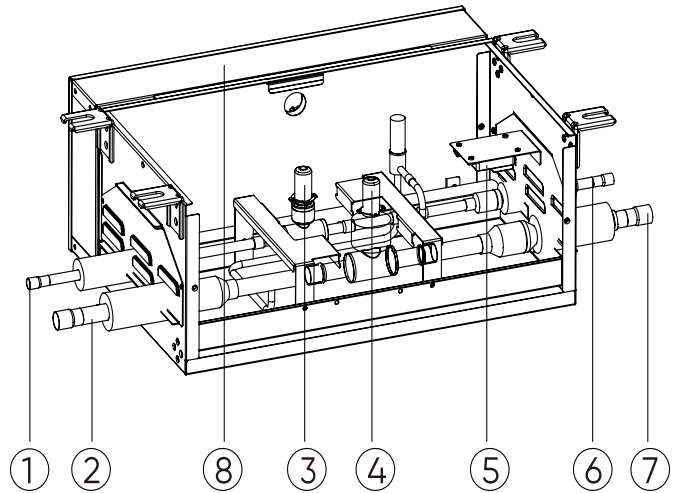
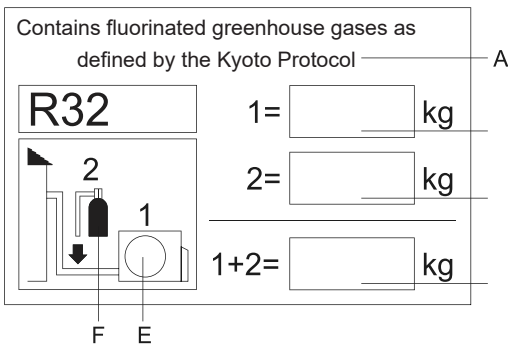

This equipment contains fluorinated greenhouse gases as defined by the Kyoto Protocol. R32 must not be released into the atmosphere.

Refrigerant type: R32  
 GWP value (GWP): 675  
 GWP=Global Warming Potential

**Write the following information on the label in indelible ink:**

1 - the factory charge of refrigerant  
 2 - the additional refrigerant charge added in the field and 1+2 - the total refrigerant charge.  
 The completed label must be affixed close to the equipment valve (e.g. on the inside of the shut-off valve cover).

A: contains fluorinated greenhouse gases covered by the Kyoto Protocol  
 B: unit's factory refrigerant charge: see unit's nameplate  
 C: additional refrigerant charge added in the field  
 D: Total refrigerant charge  
 E: Outdoor unit  
 F: Refrigerant cylinders and charging manifolds

- ① Liquid pipe (connected to outdoor unit)
- ② Gas pipe connected to outdoor unit
- ③ Liquid shut-off valve
- ④ Gas shut-off valve
- ⑤ Refrigerant leak detector
- ⑥ Liquid pipe (connected to indoor unit)
- ⑦ Gas pipe connected to indoor unit
- ⑧ PCB housing

**System layout**

- ODU: Outdoor unit
- C: Controller
- S: Shut-off valve housing
- R: Room
- IDU: Indoor unit
- CC: Centralized controller

**4 Indoor unit layout**

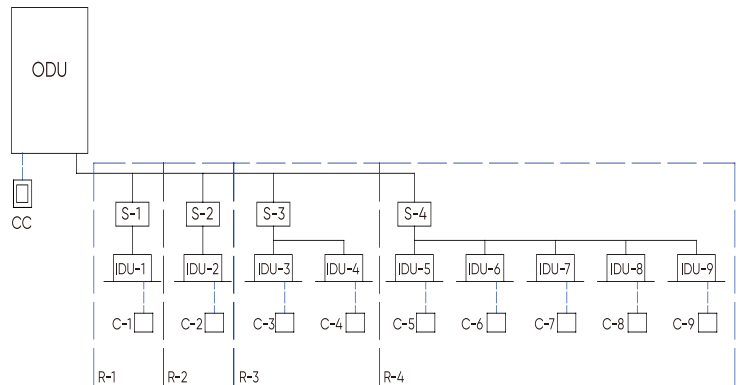

**i** The equipment is fitted with electrical safety devices such as a refrigerant leak detector. To be effective, the unit must be switched on at all times after installation, except for short term maintenance.

## Use of information

Description	ARB 01 PB1
Maximum number that can be connected to indoor units	5
Maximum power that can be connected to indoor units	16kW
Maximum number of indoor units connected to the shut-off valve box	64

## Determination of required safety measures

1. Determine the total amount of refrigerant in the
2. system.

Determine the room area where the shut-off valve box device must be installed.

Use charts to determine the safety measures required for the shut-off valve housing. Check the total amount of refrigerant in the system and the room area where the shut-off valve housing is installed to determine the safety measures that should be taken. Safety measures include alarms, safety shut-off valves, and ventilation.

4. If the housing of the shut-off valve leaks, effective measures include alarms and ventilation, including natural ventilation and mechanical ventilation.

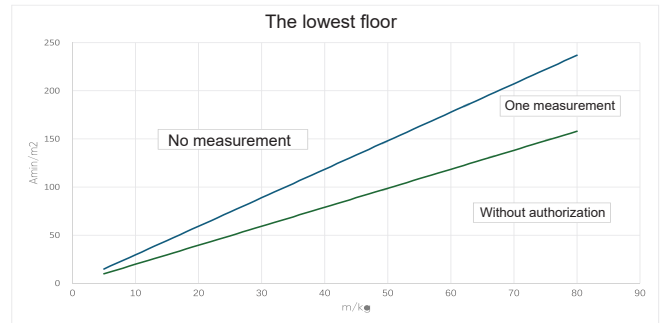
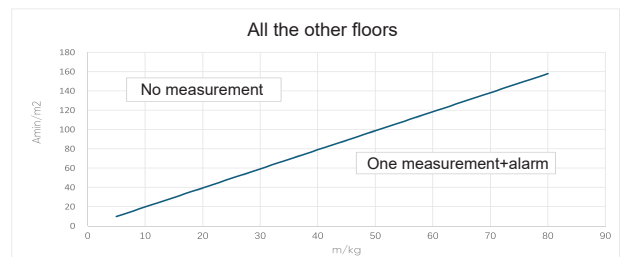

**The housing of the shut-off valve shall not be installed within 1.8m of the lowest point on the ground.**

## Other functions

The requirements for optional equipment must be proposed by the user and installed by professional after-sales service personnel.

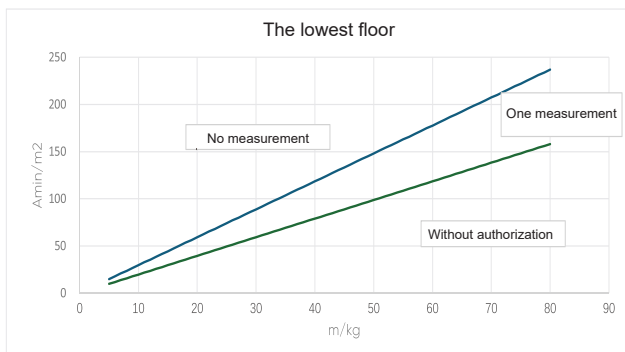
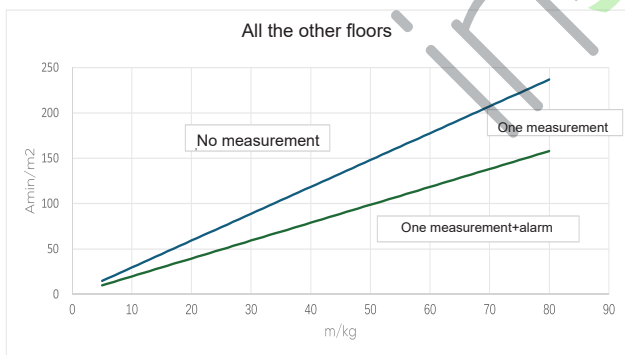

Accessory	Function	Standard or optional
R32 detector	Component for detecting refrigerant R32 leakage	Standard
R32 external detector	R32 refrigerant concentration detection and alarm	Optional

## 5.Wired Remote Control

When using R32 refrigerant in VRF systems, it is best to choose a wired controller. In fact, in the event of a leak, the controller itself can trigger an alarm. The sound emitted by the wired controller for alarm is 65 dB (A), so it is recommended not to install the equipment in a location with environmental noise higher than the alarm.



The leakage of the shut-off valve housing triggers the operation of the exhaust fan through the CN33 port on the shut-off valve housing PCB.



For more information, please refer to the operation manual.

## 6.Maintenance and Care

### 6.1.Preventive measures before any intervention



After long-term use, check whether the equipment bracket and fixation are damaged. If they are damaged, replace them.



We recommend conducting maintenance at least once a year by approved professionals.

### 6.2.In case of refrigerant leakage



The R32 detector needs to be replaced at the end of its service life (15 years). Only qualified and approved personnel can replace the detector.



- Regularly and automatically check the operation of safety measures. If a malfunction occurs, an error code will be displayed on the user interface.
- The presence of high concentration chemicals (such as organic solvents, hair gel, paint) near indoor units may distort detection.

After the end of the sensor's lifespan, the wired remote control displays an "EF" (hexadecimal) error. Whether the indoor unit is in operation or standby mode, the R32 detector will detect refrigerant leakage. If there is a refrigerant leak:

- The controller or display panel displays the error code "EA" (hexadecimal), an alarm will be triggered, and the error indicator light (LED5) on the internal PCB flashes 11 times.
- Room ventilation (natural or mechanical ventilation).
- To stop the user interface alarm, you can shut down the system after 10 minutes (if necessary, please contact the dealer).

### Replacement of detector

If the lifespan of the detector expires, please replace it

with a new one. For greater convenience, only the probe can be replaced.

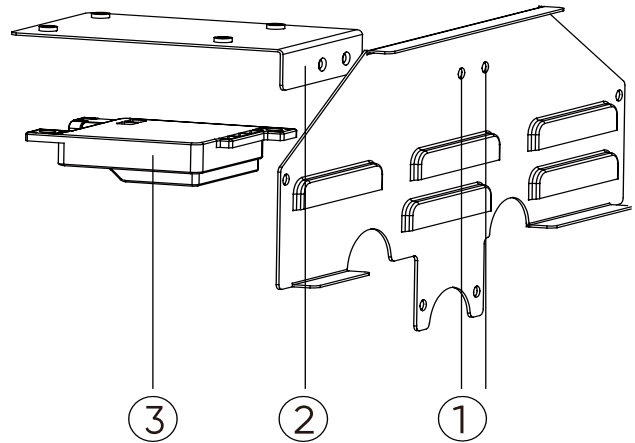

- ① Screws (2)
- ② Bracket
- ③ Refrigerant leak detector

The detector is a split type, and its cable harness and probe can be easily disassembled.

Disassembly direction

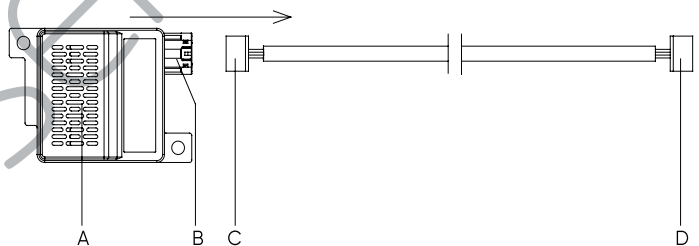

- A.Detector body
- B.Connector
- C.Terminal (connected to detector)
- D.Terminal (connected to the shut-off valve box PCB)

### Installation method

There are two installation methods for the shut-off valve housing: hanging installation or horizontal installation.

#### Hanging installation

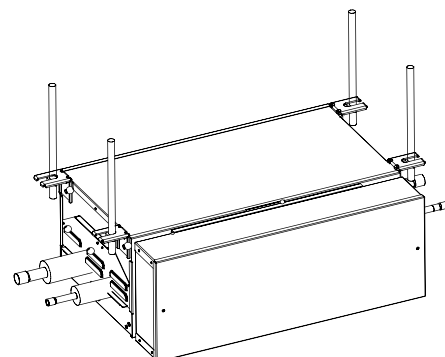

### Horizontal installation

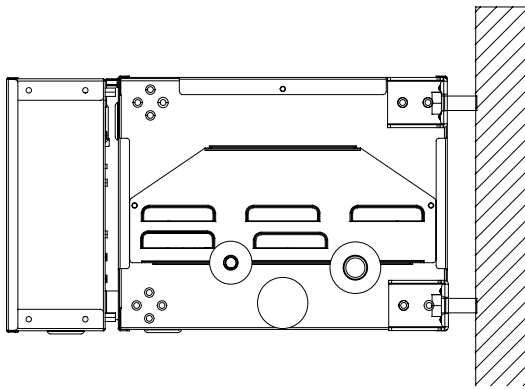

Name	Reducer pipe from Ø15.88 to Ø19.1	Reducer pipe from Ø12.9 to Ø15.88
Quantity	×2	×2
Shape		

Name	Reducer pipe from Ø9.7 to Ø15.88	Reducer pipe from Ø6.5 to Ø9.52
Quantity	×2	×2
Shape		

## 7. Troubleshooting



If any abnormal situation occurs (such as burning smell), please turn off the equipment and cut off the power. Keeping the equipment running may result in damage, electric shock, or fire.

## 8. Accessories

Name	Operation manual	Clamp ring	Diverter	Isolation condensate discharge pipe
Quantity	×1	×1	×1	×1
Shape				

Name	Clamp	Insulation component	Reducer pipe from Ø25.4 to Ø28.6
Quantity	×12	×8	×2
Shape			

Name	Reducer pipe from Ø22.22 to Ø25.6	Reducer pipe from Ø19.05 to Ø22.4
Quantity	×2	×2
Shape		

## 9. Installation of the Equipment

### 9.1. Preparation for installation site

#### Before installation

- Do not discard the spare parts required for installation before installation.
- Do not remove the packaging during installation. When it is necessary to remove the packaging, lift the equipment with soft materials or protective plates to avoid damaging the equipment or causing scratches.
- The standard accessories for this series of models are listed in the packing list. Other components required for installation shall be provided according to the company's requirements for network installation.
- When installing indoor units in very large rooms, if you want to install additional external detection alarms, please follow the installation location of the leak detector described below. Please use the recommended model for this external detection alarm.

### 9.2. Selection for installation site

The choice of site is particularly important because is a delicate operation and must be carried out by qualified by qualified personnel.

The installation site is chosen in consultation with the with the customer.



- When installing the unit, it should be easy to connect to the outdoor unit (cooling connections, condensate drain and electrical connections).
- When choosing where to install, consider how to maintain and service the unit. Leave enough space for easy access to the air conditioner, especially to remove the filter.
- Choose a thick, vibration-resistant support that can support the weight of the unit.
- The air conditioner should be installed on a bracket that can support at least 5 times the weight of the unit and the bracket should not generate noise or vibration.



- Do not install the indoor unit in the following locations:
  - By the sea, where high concentrations of salt may damage metal parts.
  - Places where substances that can damage equipment are produced, such as sulphuric acid gas, chlorine gas, acids or alkalis. Places where flammable gases, flammable carbon fibres or dust, or flammable volatile particles such as paint thinner or petrol are leaking. If gas leaks and spreads around the equipment, it may catch fire.
  - Areas where ammonia is produced.
  - Locations near heat sources, steam, amammable gases or exposed to sunlight.
  - Places where there is a risk of dangerous gas leaks.
  - Places where vibration and noise are amplified.
  - Under no circumstances should the air inlet and outlet must not be blocked. The air must be blown throughout the room.



The visual appearance of the shut-off valve box is not representative but the distances indicated must be followed.

### Dimensions of placement

#### Specific dimensions

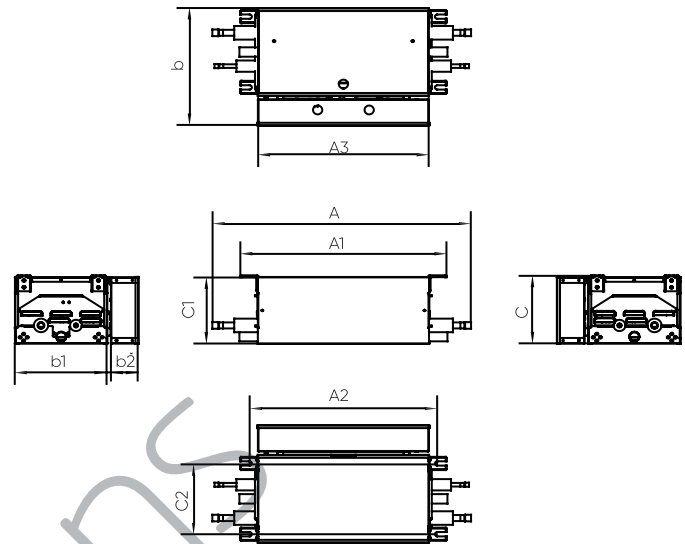

A	653mm	b	315mm	C	182mm
A1	520mm	b1	235mm	C1	178mm
A2	473mm	b2	70mm	C2	188mm
A3	435mm				

### Noise

Choose a location for the shut-off valve box where its operational noise will not disturb the occupants of the room. Maintain at least 5 meters of piping between the occupied room and the shut-off valve box. If there is no ceiling in the room, it is recommended to add deadening around the piping between the shut-off valve housing and the indoor unit, or to create a larger interval space between the two devices.

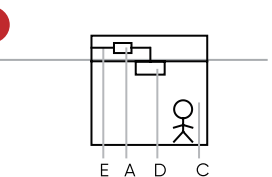
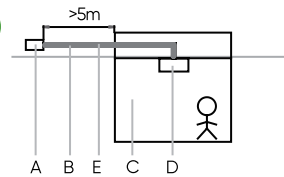

### Installation spacing

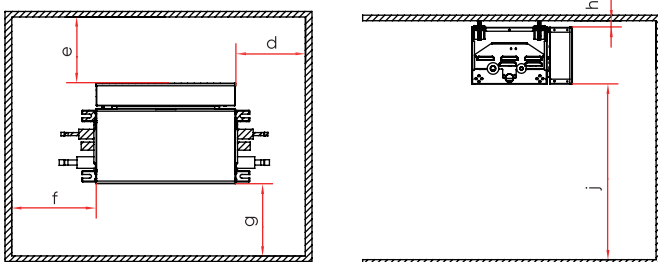

d	≥485mm	≥485mm	h	≥100mm	
e	≥720mm	g	≥500mm	j	≥1800mm

Example of the cassette installation location

- A. Shut-off valve box
- B. Deadening (powered on site)
- C. Room
- D. Indoor unit
- E. Pipe

### Mechanical ventilation

Based on the relationship curve between the refrigerant volume of the system and the room area, when the room area is relatively small, two safety measures need to be taken to respond to refrigerant leaks from the shut-off valve box. One is an alarm system, and the other is mechanical ventilation.

When there is a ceiling, and there is no air circulation between the ceiling and the room, the exhaust fan should be installed at the ceiling.

When there is no ceiling, the exhaust fan should be installed near the wall and at floor level of the room.

The air volume for mechanical ventilation in the room should be at least 130 cubic meters per hour.

When the shut-off valve box leaks, the refrigerant enters the room through its own louvers, and the exhaust fan equipped indoors is used to vent the refrigerant outdoors.

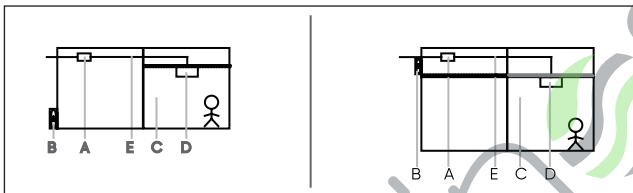

- A. Shut-off valve box
- B. Exhaust fan
- C. Room
- D. Indoor unit
- E. Pipe

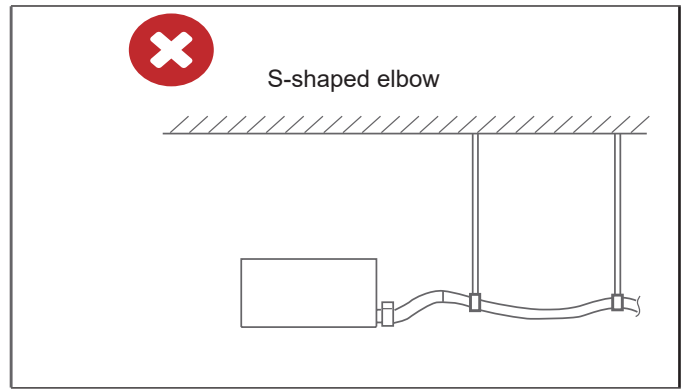

The exhaust piping of the indoor unit requires insulation. Thermal insulation must be carried out when connecting with the indoor unit. Poor insulation may lead to condensation.

The exhaust pipe with a slope at the top greater than 1/100 should not be S-shaped, as it may cause abnormal noises.

The horizontal length of the drain pipe must be controlled within 20 meters. Hanging brackets can be set every 1.5 to 2 meters to avoid uneven pipe length. Be careful not to apply external force at the connections of the exhaust pipe.



**There is no water pump in the shut-off valve box, and only natural drainage is supported.**

### Piping

The fixed pipe can be used to adjust the eccentricity and angle of the PVC pipe. Pull out the pipe for connection to avoid deformation. The flexible end of the pipe must be placed with a flange.

### Piping material and thermal insulation material

To prevent condensation, thermal insulation treatment must be carried out separately in winter.

### Thermal insulation treatment:

As shown in the picture below, wrap the exhaust pipe with thermal insulation material.

## 9.3. Installation guide for drainage pipes

### Requirements

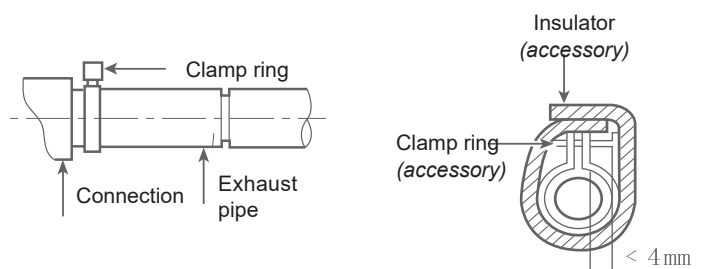
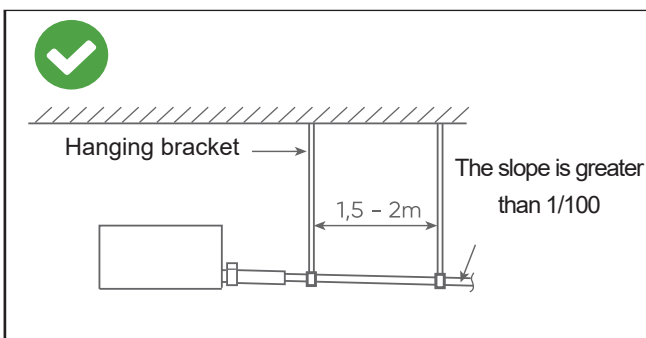

# 10. Pipe Installation

## 10.1. Preparation of the refrigerant line

### Refrigerant pipe requirements



The piping must be installed in accordance with the following instructions. Only mechanical seals that comply with the latest version of ISO 14903 can be used.



Flare connections must be used to connect the refrigerant lines.

### Refrigerant pipe diameter

Unit Model	Outer Diameter of Pipe	
	Liquid Connection Diameter	Gas Connection Diameter
SVP-160A	Ø9.52	Ø15.88

### Material and thermal insulation of refrigerant pipe

Outer Diameter	Insulated Inner Diameter	Insulation Thickness	Quenching Grade	Thickness*
6.35 mm (1/4 inch)	8~10 mm	≥10 mm	Annealing (O)	≥0.8 mm
9.52 mm (3/8 inch)	12~15 mm	≥13 mm		
12.7 mm (1/2 inch)	14~16 mm			
15.88 mm (5/8 inch)	17~20 mm			

\* Based on the applicable regulations and the maximum working pressure of the unit (see "PS High" on the unit nameplate), a thicker pipe wall is required.

When polyethylene foam is used as the thermal insulation material:

- The heat transfer rate is between 0.041 and 0.052 W/mK (0.035 and 0.045 kcal/mh°C).
- The heat resistance should be at least 120°C

If the temperature exceeds 30°C and the humidity exceeds 80%, the thickness of the thermal insulation material should not be less than 20 mm to prevent condensation on the surface of the insulation.

# 10.2. Connection of refrigerant pipe

## Connection of the Refrigerant Pipe



Install the pipe in a location where it will not be exposed to substances that can corrode refrigerant-containing components, unless the components are made of inherently corrosion-resistant material or have appropriate corrosion protection.

Follow these instructions to insulate the pipe:

- Do not use worn, deformed or discoloured adhesive.
- Use new refrigerant-grade adhesive instead.
- Use dry nitrogen to prevent the introduction of moisture that could damage the unit.
- Do not use sealant on refrigerant pipe connections as it may block or contaminate the inside of the connections. Use of sealant will void the equipment warranty.



Ensure that each refrigerant pipe is insulated.

# 11. Electrical Connection



Always use a multi-core cable for the power supply cable.

For more information, see the chapter "Warnings and Precautions".

## 11.1. Standard wiring specifications

Name		Category
Power cord	MCA*	0.3 A
	Voltage	220~240 V
	Phase	Single phase
	Frequency	50/60 Hz
	Cable size	2.5 mm <sup>2</sup> (2 cables + ground)
Transmission cable		0.75~2.0 mm <sup>2</sup> (2 cables); Max. 1000 m
Remote control cable		0.75~2.0 mm <sup>2</sup> (2 cables); Max. 400 m
Recommended circuit breaker		6 A

\*The minimum power rating. The value shown is the maximum (for the exact value, see the electrical data of the indoor unit).

## 11.2. Connecting wires to the indoor unit

**i** It's crucial to separate the power cord from the transmission line. To avoid any electrical interference, the distance between the two lines must always be at least 50 mm. Ensure that the power cord and transmission line are kept far apart. The transmission line and power cord can cross, but they must not run parallel.

### Notes:

Only copper wires should be used. A circuit breaker should be provided; otherwise, it may lead to electric shock.

Ensure that the wires do not come into contact with any hot parts of the pipe to avoid melting the cable insulation. After connection, the pipe must be bent into a U-shape and fixed with a clamp.

The controller wiring and refrigerant piping can be arranged and fixed together.

Before any intervention, please cut off the power supply. Seal the packaging holes with thermal insulation material to prevent condensation water.

The signal line and the power cord are separate.

### Example of the complete system

The wiring of the transmitter and controller is as follows:

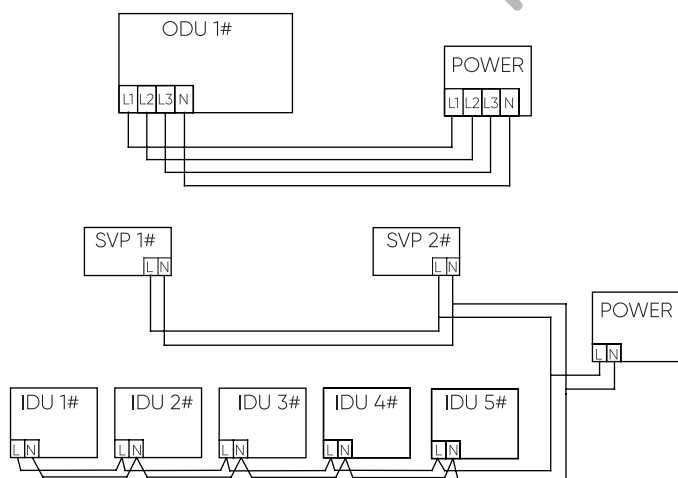

- i** The indoor unit and the outdoor unit must be connected to the power source separately. The shut-off valve housing and the indoor unit share a common power source.
- Indoor units should share a common power source, but their capacity and specifications should be taken into account.
- Both indoor and outdoor units must be equipped with leakage circuit breakers and overflow protection circuit breakers.

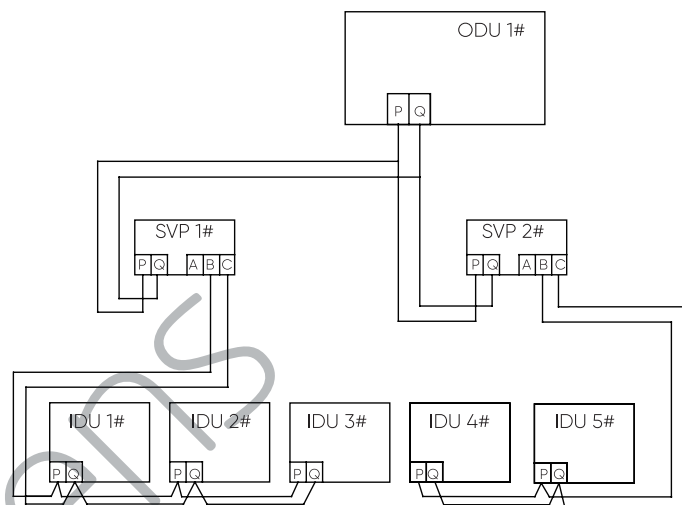

Wiring for indoor unit power cords, wiring between indoor and outdoor units, and wiring between indoor units:

Total Current of Indoor Unit (A)	Cross Section (mm <sup>2</sup> )	Length (m)	Rated Current of Overcurrent Circuit Breaker (A)	Rated Current of Residual Current Circuit Breaker (A); Ground Fault Switch (mA); Response Time (s)
<6	2.5	20	6	6 A, 30 mA, 0.1 second or less
≥6 and <10	2.5	20	10	10 A, 30 mA, 0.1 second or less
≥10 and <16	4	25	16	16 A, 30 mA, 0.1 second or less
≥10 and <25	6	30	25	25 A, 30 mA, 0.1 second or less
≥25 and <32	10	50	32	32 A, 30 mA, 0.1 second or less

The power cord and the signal line must be tightly connected.

Each indoor unit must be grounded.

It is necessary to adjust the cross section of the power cord according to its length.

The total length of the communication line must not exceed **1,000 meters**.

## 12. Debugging

### 12.1. Pre-debugging checklist

After installing the equipment, check the following points first:

The indoor and outdoor units are installed correctly.

Ensure that the drainage pipe is installed correctly, insulated, and drains smoothly.

Check for any water leaks.

The refrigerant pipe (gas and liquid) is installed correctly and insulated.

The system is properly grounded, and check for any phase loss or phase reversal.

According to the installation instructions, the locally installed fuse or protective equipment is in place.

The power voltage matches the voltage indicated on the equipment identification label.

Check the switch box for any loose connections or damaged electrical components.

Check the indoor and outdoor units for any damaged parts or crushed pipes.

The shut-off valves (gas and liquid) on the outdoor unit are fully open.

The indoor unit is equipped with an R32 detector.

### 12.2. Error code for indoor unit

Error Code Displayed on the Remote Controller	PCB LED5	Fault Description
EA	11	Refrigerant leak detection for shut-off valve box
Eb	11	Reduction in refrigerant concentration
Ec	19	Communication interruption between detector and circuit board in shut-off valve box
Ed	19	Self-check abnormality of the detector in shut-off valve box
EE	19	The service life of the detector in shut-off valve box is about to end (180 days in advance)
EF	19	The detector in shut-off valve box has reached its service life

## 13. Equipment System Diagram

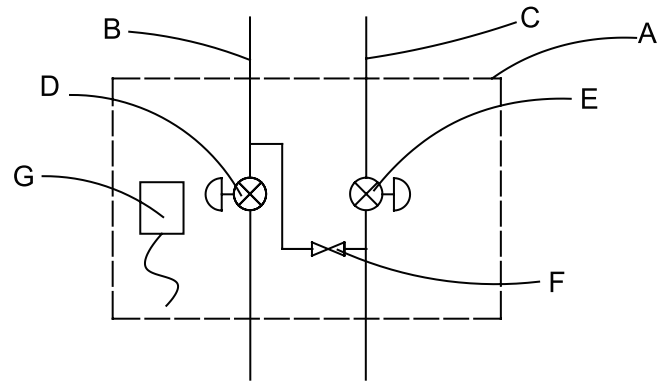

- A. Shut-off valve housing
- B. Gas pipe
- C. Liquid pipe
- D. Air shut-off valve
- E. Liquid shut-off valve
- F. Discharging valve
- G. Refrigerant leak detector

insens



Qingdao Haier Air Conditioner Electric Co.,Ltd.

Haier Industrial Park,Qianwangang Road,Eco-Tech Development Zone,Qingdao 266555,  
Shandong,China