

# Installation Manual for Outdoor Unit



AU032FSEUA

AU052FPEUA

AU072FPEUA

No. 0150541142

- This product must only be installed or serviced by qualified personnel.  
Please read this manual carefully before installation.  
**Keep this operation manual for future reference.**  
Original instructions



# User Manual

## Contents

Product Features .....	1
Safety .....	1
Transportation and Lifting .....	3
Installation instruction .....	4
Electric wiring and the application .....	14
Installation and debugging.....	18
Failure code.....	19
Trial operation and the performance .....	22
Move and scrap the air conditioning.....	24

## Important matters

- The company does not assume any responsibility for the accidental damage caused by the operation of the air conditioner in a particular environment.
- The air conditioner can only be used as an ordinary air conditioner.
- Do not use this heat pump air conditioner for dry clothing, frozen food, cooling or heating, etc.
- No part of this manual may be copied without permission.
- Bold text (warning, prohibition, attention) used to indicate the degree of risk. The following is a description of the text and symbols in the explanatory notes:

	<b>WARNING:</b> Indicates a potentially hazardous situation which, if not avoided, will result in death or serious injury.
	<b>PROHIBIT:</b> Do not carry out the operation.
	<b>CAUTION:</b> Sometimes it can cause serious accidents.

- If you have any questions, please contact the dealer or the service center designated by our company.
- Please install air conditioning in accordance with local standards.

## CE

All the products are in conformity with the following European provision:

- Low voltage Directive
- Electromagnetic Compatibility

## Warning

- If the supply cord is damaged, it must be replaced by the manufacturer, its service agent or similarly qualified persons in order to avoid a hazard.
- This appliance is not intended for use by persons (including children) with reduced physical, sensory or mental capabilities, or lack of experience and knowledge, unless they have been given supervision or instruction concerning use of the appliance by a person responsible for their safety.
- Children should be supervised to ensure that they do not play with the appliance.
- This appliance can be used by children aged from 8 years and above and persons with reduced physical, sensory or mental capabilities or lack of experience and knowledge if they have been given supervision or instruction concerning use of the appliance in a safe way and understand the hazards involved. Children shall not play with the appliance. Cleaning and user maintenance shall not be made by children without supervision.
- The appliances are not intended to be operated by means of an external timer or separate remote-control system.
- Keep the appliance and its cord out of reach of children less than 8 years.

## Operation condition:

To use the air conditioner normally, please perform as to the below conditions.

### Operating Range of Air Conditioner

Cooling dry	Indoor	Max.	DB:32°C	WB:23°C
		Min.	DB:18°C	WB:14°C
	Outdoor	Max.	DB:50°C	WB:26°C
		Min.	DB:-5°C	
Heating	Indoor	Max.	DB:27°C	
		Min.	DB:15°C	
	Outdoor	Max.	DB:27°C	WB:15°C
		Min.	DB:-20°C	

# Product Features

---

- The outdoor unit adopts "simultaneous control" type, all indoors should be heating or cooling simultaneously.
- To protect compressor, before startup, the unit should be electrified for 12 hours. If the unit is not used for a long time, please cut off the power to save energy, or the unit will consume the power.

This manual describes the installation and installation of outdoor units. For the installation of the indoor machine, please refer to the instruction manual of the indoor machine.

Please read the installation instructions carefully before installation, according to the instructions of the installation construction.

## Safety

---

- If the air conditioner is transferred to the others, this manual should be transferred together.
- Before installation, please read "Safety precaution" carefully to confirm the correct installation.
- The mentioned precaution includes "⚠WARNING" and "⚠CAUTION". The precaution caused death or heavy injury for faulty installation will be listed in "⚠WARNING". Even the cautions listed in "⚠CAUTION" also may cause serious accident. So both of them are related to the safety, and should be executed severely.
- After installation, perform a trial and confirm everything normal, then introduce the operation manual to the user. Besides, put the manual to the user and ask them to preserve it carefully.

### ⚠WARNING

- The installation or the maintenance should be performed by the authorized agency. Or the non-specialized operation will cause water leakage, electric shock or fire etc accidents.
- The installation should be executed as per the manual, or the faulty installation will cause water leakage, electric shock or fire etc accidents.
- Please install the unit at the space which can bear the weight. Or the unit will drop down to cause the human injury.
- The installation should defend against the typhoon, and the earthquake etc. Abnormal installation will cause the unit fall down.
- Use the correct cable and make reliable earthing. Fix the terminal firmly and the loose connection will cause heating or fire etc accident.
- The wiring should be in shape and can not be raised. Be earthed firmly and can not be clipped by the electric box cover or the other plate. The incorrect installation will cause heating or fire.
- When setting or transferring the unit, there should not be other air into the refrigerant system except for R410A. The gas mixture will cause the abnormal high pressure which will cause break or human injury etc accidents.
- When installation, please use the accessories with the unit or the special parts, or it will cause water leakage, electric shock, fire, refrigerant leakage etc accidents.
- Don't lead the water drainage pipe into the drainage groove with the poisonous gas, such as sulphur. Or the poisonous gas will enter indoor.
- In installation or after installation, please confirm if there is refrigerant leakage, please take measures for ventilation. The refrigerant will cause poisonous gas as meeting fire.
- Don't install the unit at the place where there may be flammable gas leakage. In case the gas leaks and gather around the unit, it will cause fire.
- The drainage pipe should be installed as per the manual to confirm the fluent drainage. Also take measures for heat insulation against dew drop. Incorrect water pipe installation will cause water leakage even and make the things wet.
- For the liquid pipe and the gas pipe, take measures for heat insulation too. If there is no heat insulation, the dew drop will wet the things.

### ⊘ PROHIBIT

- This system using R410A refrigerant, prohibit filling oxygen, acetylene or other flammable and toxic gases in the air or test, because these gases are very dangerous and may cause explosion. It is recommended to use compressed air, nitrogen or refrigerant for such tests.
- Indoor or outdoor machines are not allowed to water. All of these products are equipped with electrical components, which may cause serious electric shock accidents.
- Do not touch or adjust the safety device in the indoor or outdoor machine. If touching or adjusting these devices can cause serious accidents.

# Safety

- The maintenance cover plate of the indoor or outdoor machine is forbidden when the main circuit power supply is not cut off.
- The leakage of refrigerant can cause the air to be thin and difficult to breathe. In case of refrigerant leakage, close the main valve, extinguish any flame and contact the local distributor immediately.
- Please use ELB (leakage protector). If not used, an electric shock or fire may occur when an accident occurs.
- The installation and Service Engineer shall ensure that the refrigerant leaks comply with local laws and regulations.

## ⚠CAUTION

- Execute earthing for the unit. But the earthing wire can not be connected to the gas pipe, water pipe, lightning rod or the telephone earthing wire. Improper earthing will cause electric shock.
- Don't install the unit at the place where leaks the flammable gas. Or it will cause fire.
- Execute the water drainage pipe according to the manual, improper installation will cause water leakage to wet the family things.
- The outdoor fan can not face to the flower or the other vegetable, or the blowing gas will make the flower dried up.
- Please ensure the maintenance room, if not, it will cause the maintenance person damaged.
- When installing the unit on the roof or the other high place, to prevent the person falling down, please set the fixed ladder and the railing at the passage.
- Use the two-end spanner, and fasten the nut at proper torque. Don't fasten the nut excessively against the flared section broken. Or it will cause refrigerant leakage and lack of oxygen.
- Take measures for heat insulation to the refrigerant pipe, or there will be water leakage or dew drop to wet the family things.
- After finishing the refrigerant pipe, make leakage test by charging the nitrogen. In case the refrigerant leaks in a small room and exceeds the limited concentration, it will cause lack of oxygen.
- Don't use the other refrigerant except for R410A. The R410A pressure is 1.6 times higher than R22 pressure. The refrigerant R410A tank is marked with pink sign.
- Against charging different refrigerant, we changed the stop valve diameter of the R410A unit. To enhance the compression consistence, we also changed the flared pipe dimension. Prepare the R410A specially tools according to the below table.

	R-410A specified tools	Remarks
1	Gauge manifold	Range: HP > 4.5MPa, LP > 2MPa
2	Charge hose	Pressure: HP: 5.3MPa, LP: 3.5MPa
3	Electronic balance for charging R410A	Can not use the measurable charging tank
4	Torque spanner	
5	Flare tool	
6	Copper pipe gauge for adjusting projecting margin	
7	Vacuum pump adapter	Must be with reverse stop valve
8	Leakage detector	Can not use freon leakage detector, but the He detector

- When charging refrigerant, the refrigerant must be taken out as liquid state from the tank.
- When installing the power cord and the connecting line must be at least 1m from the TV or radio, so as to avoid image interference or noise.
- In the room with fluorescent lamp (reverse or fast start type), remote control signal transmission distance may not reach the predetermined value, so the indoor machine installed away from the fluorescent lamp as far as possible.
- Please use the fuse to meet the capacity requirements.
- To prevent the destruction of wires, electrical components, etc. by rats or other animals.
- Recommended room ventilation every 3 to 4 hours.

### Arrival inspection

- After receiving the machine, should check whether there is transport damage. If any damage is found on the surface or inside, it shall be reported immediately to the shipping company in writing.
- Check the product model, electrical parameters (power supply, voltage, frequency) and accessories to determine whether they meet the requirements.

# Transportation and Lifting

## Lifting

In front of the unit shipped from unpacking location as close as possible.

### ⚠ CAUTION

- Do not place anything on the device.
- Two ropes shall be used for lifting the outdoor unit.

### Hoisting method

Hoisting to ensure that the level of outdoor machine, slowly lifting.

1. Removal of outer packing is strictly prohibited
2. As shown by two ropes hoist with outdoor machine packaging.

### ⚠ CAUTION

- In order to ensure safety, maintain the level of lifting, slowly lifting.
- Do not lift the elevator to the packing and outer packing of the equipment.
- External protection should be used when lifting, such as cloth or cardboard.

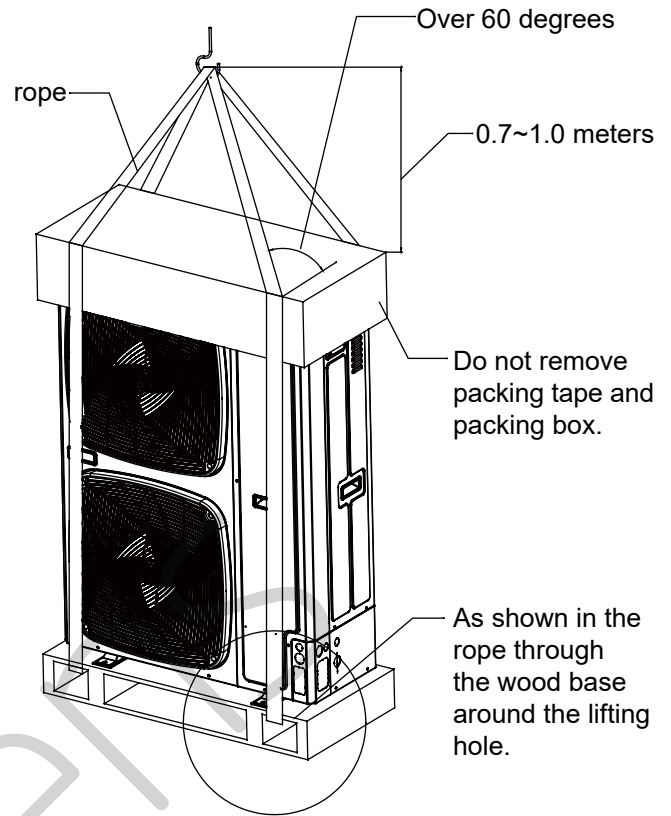

## Manual handling

### ⚠ CAUTION

- In the installation and commissioning, the outdoor machine do not put any irrelevant material, to ensure that there is no debris inside the machine, or there may be a fire or accident.

Pay attention to the following points when handling the equipment manually:

1. No demolition wood base.
2. In order to prevent the dumping of the outdoor machine, the center of gravity of the unit should be noted as shown in the figure.
3. Two or more people to carry out the outdoor machine.

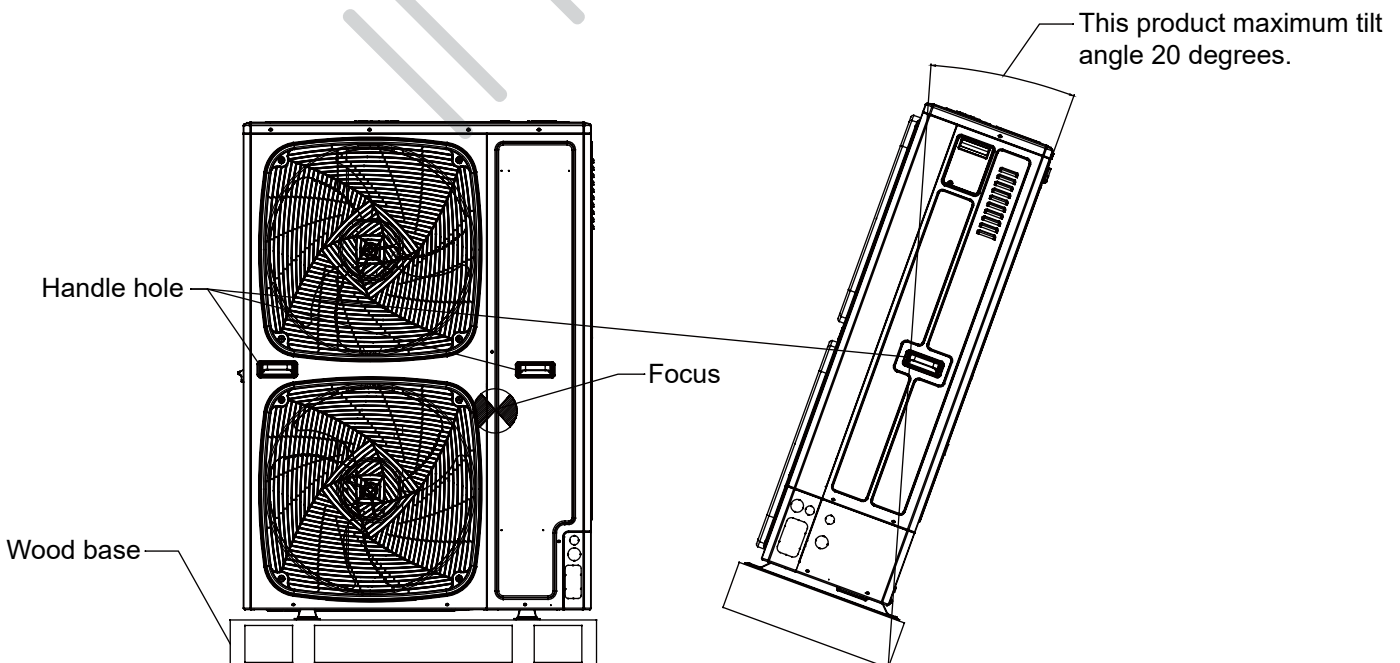

# Installation instruction

In installation, please check specially the below items:

- If the connected units quantity and the total capacity is in the allowable range?
- If the refrigerant pipe length is in the limited range?
- If the pipe size is proper? And if the pipe is installed horizontally?
- If the branch pipe is installed horizontally or vertically?
- If the additional refrigerant is counted correctly and weighed by the standard balance?
- If there is refrigerant leakage?
- If all the indoor power supplies can be on/off simultaneously?
- If the power voltage is in compliance with the data marked on the rating label?
- If the address of indoors has been set?

## (1) Before installation

- 1) Before installation, check if the model, power supply, pipe, wires and parts purchased respectively are correct.
- 2) Check if the indoors and outdoors can be combined as the following.



Outdoor		Indoor	
Capacity (100w)	Combination type	Indoor qty	Total indoor capacity (100w)
80	Single	4	40-104
140	Single	8	70-182
180	Single	9	90-234

indoor capacity (100W)	total indoor capacity (100W)	branch pipe (optional)
22	less than 335	FQG-B335A
28		
36		
40		
45		
56		
71		

Notice:

- Total capacities of indoor units being used  $\leq 100\%$  of rated capacities of outdoor unit.
- The maximum number and total capacity of indoor units are shown in the table above. If the total capacity of the indoor units is greater than the rated capacity of the outdoor unit, the actual cooling or heating effect of each indoor units may not reach its rated capacity.

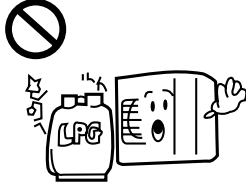
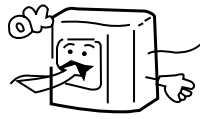
## (2) Installation place selection

<p>Air-conditioner can't be installed in the place with inflammable gas. Or it will cause fire hazard.</p> 	<p>The unit should be installed at the place with good ventilation. No obstacle at the air inlet/outlet. And no strong wind blows the unit.</p>  <p>The installation space refers to the latter info.</p>	<p>The unit should be installed at the strong enough place. Or it will cause vibration and noise.</p> 
<p>The unit should be installed at the place where the cold/hot air or noise will not interfere the neighbours.</p> 	<ul style="list-style-type: none"> <li>• The place where the water can flow fluently.</li> <li>• The place where no other heat source will affect the unit.</li> <li>• Pay attention to the snow against clogging the outdoor.</li> <li>• In installation, install the anti-vibration rubber between the unit and the bracket.</li> </ul>	<ul style="list-style-type: none"> <li>• The unit is better not be installed at the below places, or it will cause damage.</li> <li>• The place where there is corrosive gas (spa area etc).</li> <li>• The place blowing salty air (seaside etc).</li> <li>• Exsits the strong coal smoke.</li> <li>• The place with high humidity.</li> <li>• The place where there is device emitting Hertzian waves.</li> <li>• The place where voltage changes greatly.</li> </ul>

# Installation instruction

Note:

1. In snowy area, install the unit under the bracket or the snow-proof cover against the accumulative snow on the unit.
2. Do not install the unit at the place where the flammable gas will leak.
3. Install the unit at the strong enough place.
4. Install the unit at the flat place.
5. When being installed at the place with strong wind, set the air outlet of the unit and the wind direction vertical.
6. The installation site should be far away from the place where the noise is higher. At the same time for the noise of higher places should ensure that the outdoor machine vibration and wall insulation measures to prevent vibration caused by thin wall or acoustic noise problems.
7. Aluminum foil fin is very sharp, pay attention to prevent scratches.
8. In addition to the maintenance of the roof, or the installation of outdoor machines, other people can not contact the outdoor machine.

## (3) Installation and maintenance space

### Selection of installation location of outdoor

(1) Single-unit installation (unit: in.(mm))

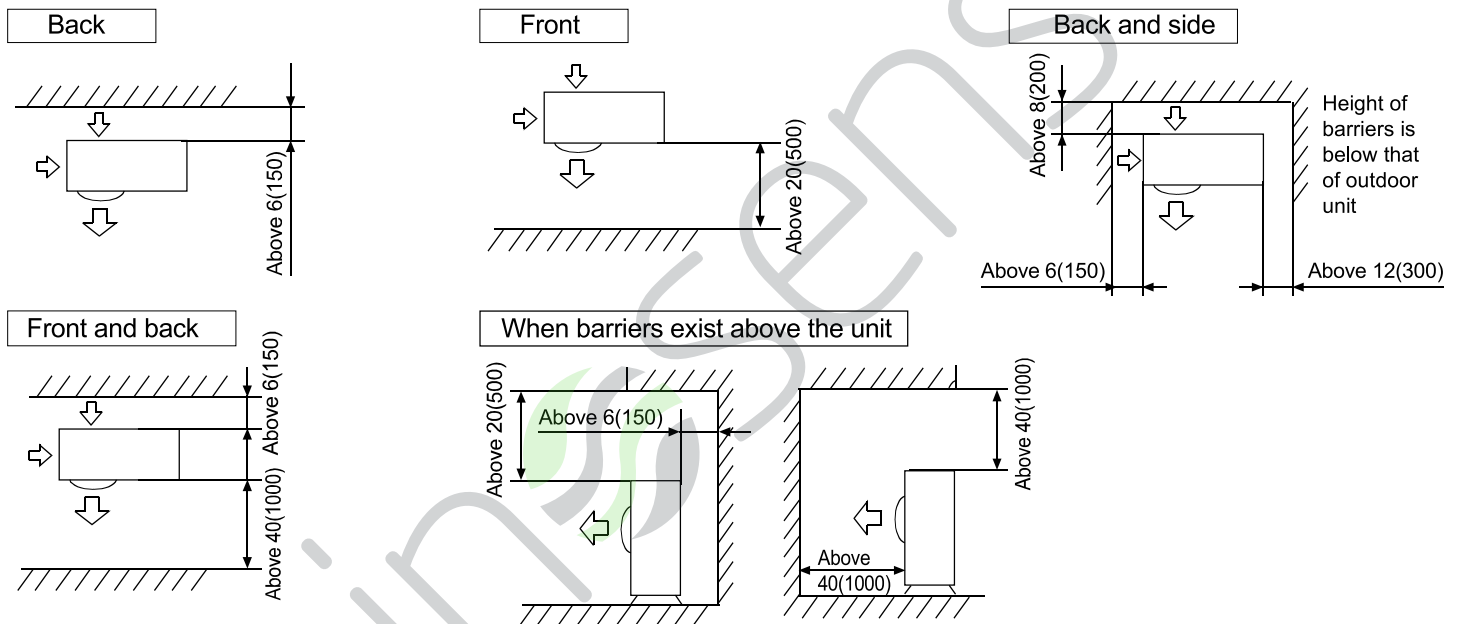

The top and two side surfaces must be exposed to open space, and barriers on at least one side of the front and back shall be lower than the outdoor unit.

(2) Multi-unit installation (unit: in.(mm))

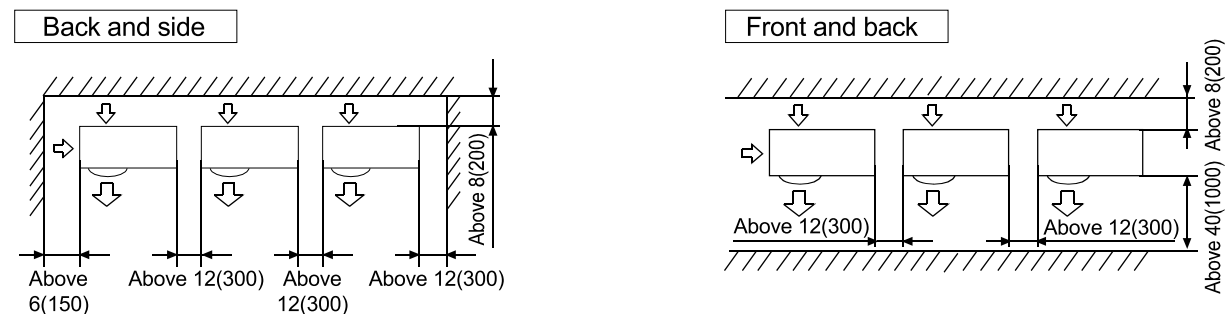

Height of barriers is below that of outdoor unit

# Installation instruction

## (3) Multi-unit installation in front and back (unit: in.(mm))

Standard

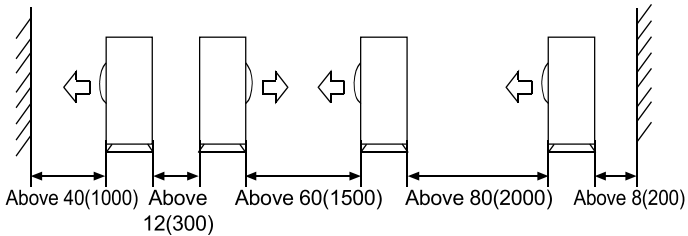

The top and two side surfaces must be exposed to open space, and barriers on at least one side of the front and back shall be lower than the outdoor unit.

- The installation service spaces shown in the illustrations are based on an air intake temperature of 95°F(35°C)(DB) for COOL operation. In regions where the air intake temperature regularly exceeds 95°F(35°C)(DB), or if the heat load of outdoor units is expected to regularly exceed the maximum operating capacity, reserve a larger space than that indicated at the air intake side of units.
- Regarding the required air outlet space, position the units with consideration to the space required for the onsite refrigerant piping work as well. Consult your dealer if the work conditions do not match those in the drawings.

## (4) Precautions on installation

### NOTICE

If drain holes of the outdoor unit are covered by a mounting base or by floor surface, raise the unit in order to provide a free space of more than 5in.(130mm) under the outdoor unit.

### Foundation work

- Check the strength and level of the installation ground so that the unit will not cause any operating vibration or noise after installation.
- In accordance with the foundation drawing in the figure, fix the unit securely by means of the foundation bolts.
- It is best to screw in the foundation bolts until their length are 0.8in.(20mm) from the foundation surface.

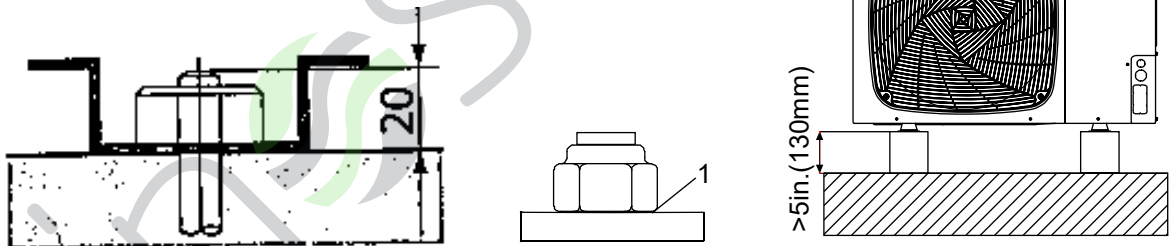

- Fix the outdoor unit to the foundation bolts using nuts with resin washers(1) as shown in the figure.
- If there is no need to install the outdoor machine in the open space of the building or the enclosure, the following two ways can be used to avoid the fan reversal or damage caused by strong wind blowing.

### (1) Using the windshield

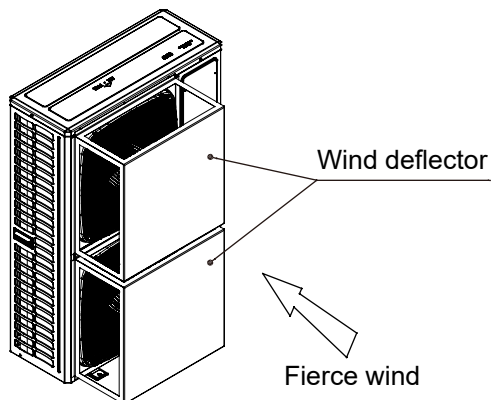

### (2) Near wall installation

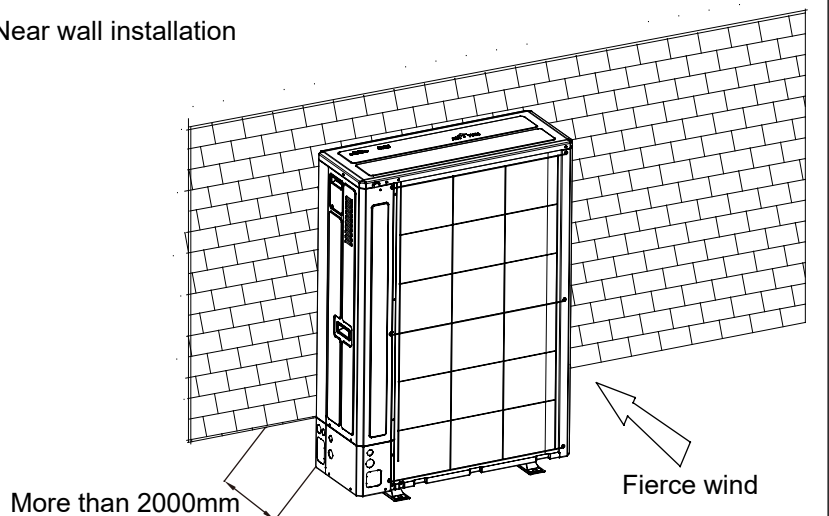



# Installation instruction

If the coating on the fastening area is stripped off, the nuts rust easily.

Dimensions (bottom view) (unit of measurement: mm)

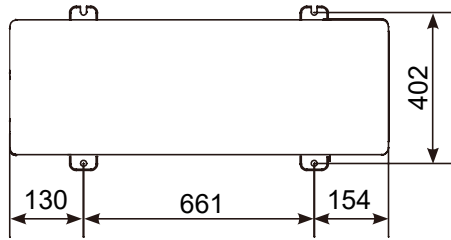

AU032FSEUA

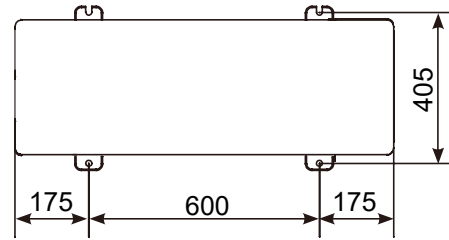

AU052FPEUA  
AU072FPEUA

## (5) Refrigerant pipe connection

### Pipe connection method:

- To ensure the efficiency, the pipe should be as short as possible.
- Daub the refrigerant oil on the connector and the flare nut.
- When bending the pipe, the bending semi-diameter should be as large as possible against the pipe being broken or bent.
- When connecting the pipe, aim at the center to thread the nut by hand and tighten it with the double spanners.
- Don't let the impurity such as sand, water etc into the pipe.

When fastening and loosening the nut, operate with double spanners, because only one spanner cannot execute firmly.

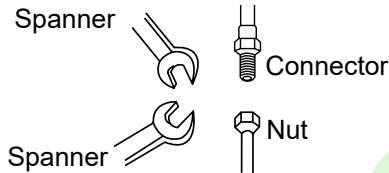

If threading the nut as not aiming at the center, the screw thread will be damaged, further it will cause leakage.

### Cautions in piping installation:

- When welding the connector with hard solder, charge nitrogen into the pipe against oxidation. Or the oxygen film in the pipe will clog the capillary and the expansion valve, even cause the deathly accident.
- The refrigerant pipe should be clean. If the water and the other impurity enter the pipe, charge the nitrogen to clean the pipe. The nitrogen should flow under the pressure of about 0.5Mpa and when charging the nitrogen, stop up the end of the pipe by hand to enhance the pressure in the pipe, then loose the hand (meanwhile stop up the other end).
- The piping installation should be executed after the stop valves are closed.
- Before welding the valve and the pipes, use the wet cloth to cool down the valve and the pipes.
- When the connection pipe and the branch pipe need to be cut down, please use the special shears and cannot use the saw.

### Pipe material and specs selection

1. Please select the refrigerant pipe of the below material.  
Material: the phosphoric oxidize seamless copper pipe, model: C1220T-1/2H (diameter is over 19.05); C1220T-0 (diameter is below 15.88).
2. Thickness and specs:  
Confirm the pipe thickness and specs according to the pipe selection method(the unit is with R410A, if the pipe over 19.05 is 0-type, the pressure preservation will be bad, thus it must be 1/2H type and over the min. thickness).
3. The branch pipe must be from Haier.
4. When installing the stop valve, refer to the relative operation instruction.
5. The pipe installation should be in the allowable range.
6. The installation of branch pipe and gather pipe should be performed according to the relative manual.

# Installation instruction

## Drain pipe disposal

- Make sure the drain works properly.
- In regions where buildups of snow can be expected, the accumulation and freezing of snow in the space between the heat exchanger and external plate may lower operating efficiency.
- After punching the knock-out hole, the application of repair-type paint on the surface around the edge sections is recommended to prevent rust.

## Pipe specification:

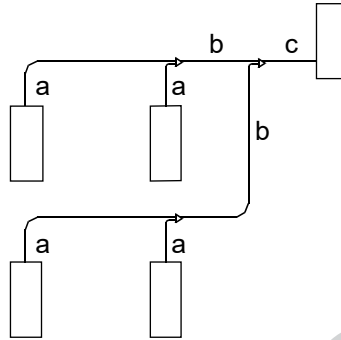

1. Pipe "a" diameter (between indoor and branch pipe) (depends on indoor pipe)  
Please refer to the indoor air conditioner manual.

2. Pipe "b" diameter (between branch pipes)

Total indoor capacity after the branch pipe (x100W)	Gas pipe (mm)	Liquid pipe (mm)
$X < 112$	Ø15.88	Ø9.52
$112 \leq X < 234$	Ø19.05	Ø9.52

3. Pipe "c" diameter ( outdoor pipe diameter)

Outdoor capacity (100W)	Gas pipe (mm)	Liquid pipe (mm)
80	Ø15.88	Ø9.52
140	Ø19.05	Ø9.52
180	Ø19.05	Ø9.52

Note:  
When the distance from outdoor to the longest indoor is over 30m, the main pipe should be the enlarged diameter.

Copper pipe selection:

hardness	softness				Half-hardness			
Outer diameter (mm)	Ø6.35	Ø9.52	Ø12.7	Ø15.88	Ø19.05	Ø22.22	Ø25.24	Ø28.58
Min. thickness (mm)	0.8	0.8	1.0	1.0	1.0	1.1	1.2	1.4

Note:  
If the copper pipe with outer diameter 19.05 is coil pipe, the thickness should be over 1.1.

# Installation instruction

## Piping connection method:

### Outdoor unit with single fan piping connection method

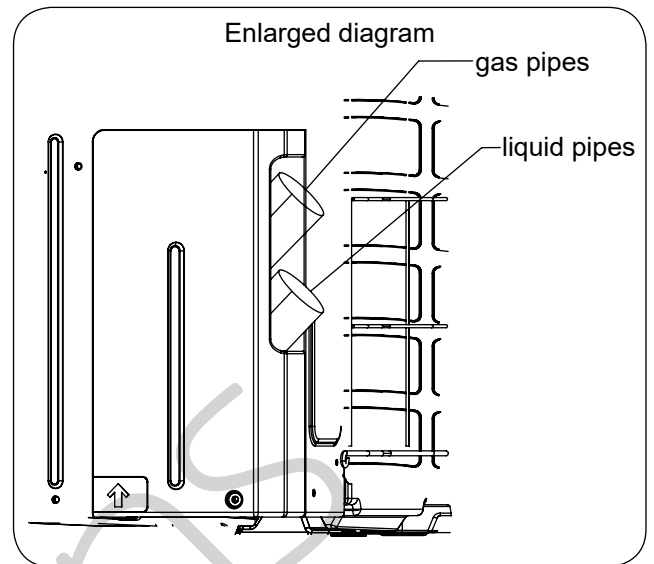
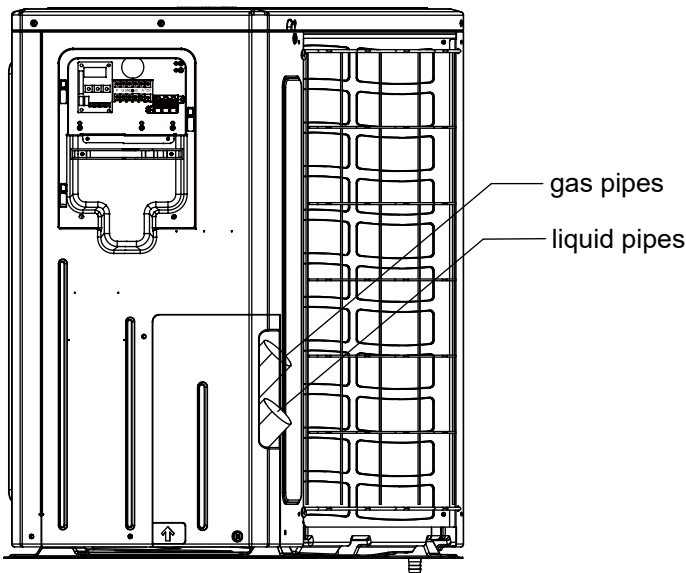

### Outdoor unit with double fan piping connection method Pipes can be connected in four directions

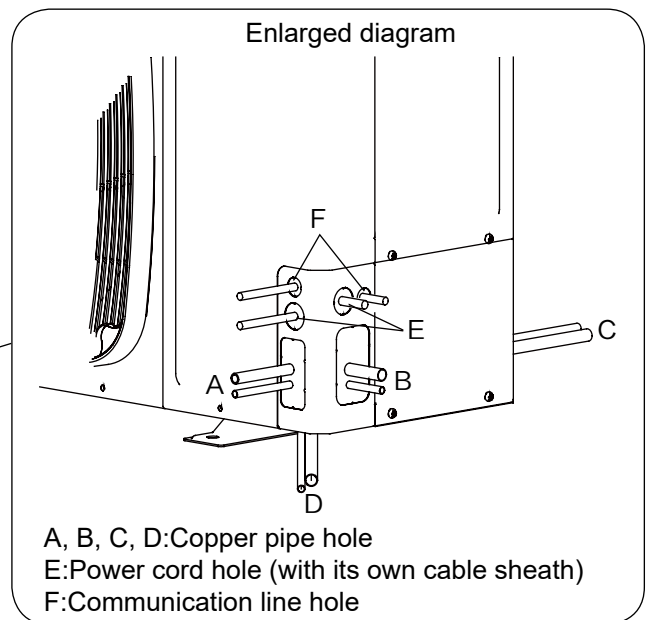
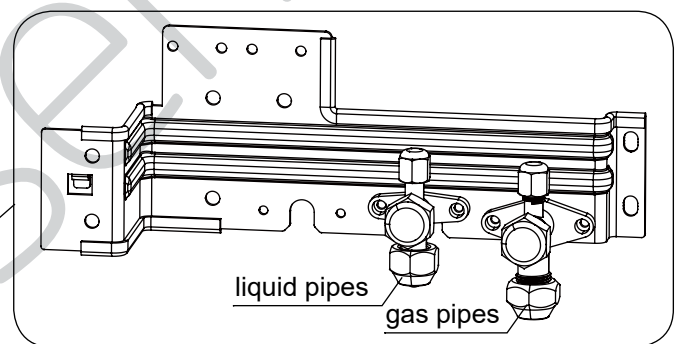
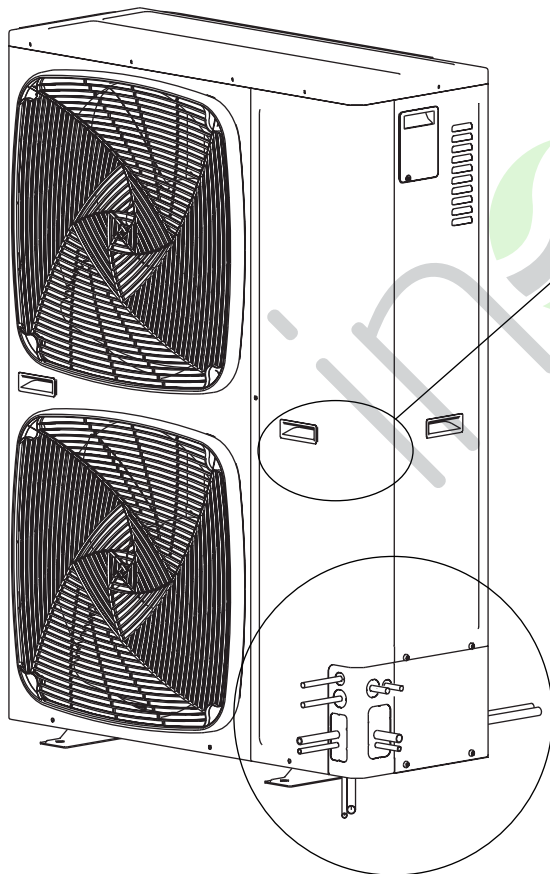

As shown in the figure, the piping can be connected from four directions. Through the front / rear hole piping on the cover hole or crack directly across the floor. From the outdoor machine unloading piping cover with a screwdriver and hammer knock off holes along the guide wire break. Then, trim the edges of the holes, and mounted on the insulating sleeve (site) to protect the piping and wiring.

# Installation instruction

## Long pipe and high drop

### 1. Allowable pipe length and height difference

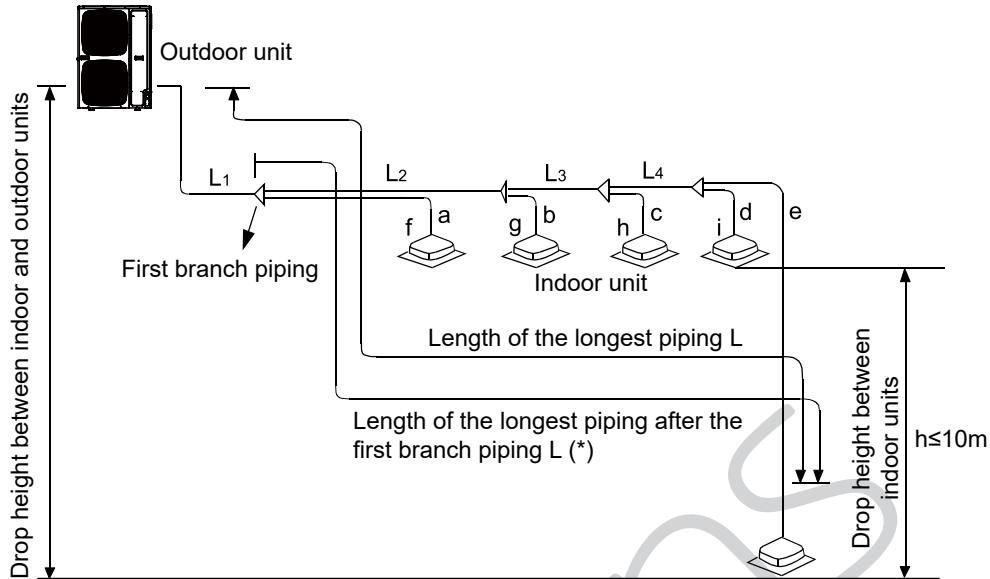

### Maximal length and drop height permissible of refrigerant piping

Piping length	Total length of piping (actual length)	Permissible value		Piping part
		80	120m	
		140/180	150m	L1+L2+L3+L4+a+b+c+d+e
	Longest piping L	60/70m		L1+L2+L3+L4+e
	Piping length of indoor unit which is furthest to the first branch piping L (*)	40m		L2+L3+L4+e
Drop height	Drop height between indoor and outdoor unit H	Up outdoor	50m	—
		Under outdoor	40m	—
	Drop height between indoor units h	10m	—	

## Unit pipe spec and connection method (unit: mm)

### A. Outdoor unit

Model	Gas pipe side		Liquid pipe side	
	Diameter (mm)	Connecting method	Diameter (mm)	Connecting method
AU03	Ø15.88	Flared joint	Ø9.52	Flared joint
AU05	Ø19.05		Ø9.52	
AU07	Ø19.05		Ø9.52	

### B. Indoor unit

Please refer to the indoor air conditioner manual.  
Connecting method: Flared joint

## Branch pipe

Outdoor unit type

Branch pipe selection:

Total indoor capacity (100W)	Model (optional)
Less than 335	FQG-B335A

### C. Pipe spec and the torque

Diameter (mm)	Thickness (mm)	Torque (N.m)
Ø6.35	0.8	16~20
Ø9.52	0.8	40~50
Ø12.7	1.0	
Ø15.88	1.0	90~120
Ø19.05	1.0	100~140
Ø22.22	1.1	—
Ø25.4	1.2	—
Not less than Ø28.58	More than 1.4	—

Note: If the copper pipe with outer diameter 19.05 is coil pipe, the thickness should be over 1.1.

# Installation instruction

Note:

1. When connecting the pipe and the outdoor, please pay attention to the outdoor pipe dimension.
2. When adjusting the diameter among pipes and among the units, please must execute at the branch pipe side.
3. When welding with hard solder, please must blow nitrogen. If not, a number of oxide will be produced and cause heavy damage. Besides, to prevent water and dust into the pipe, please make the brim as outer roll.

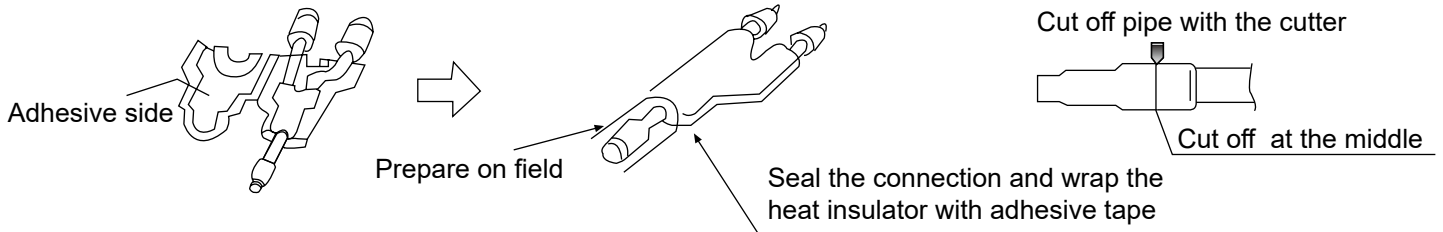

## Heat insulation

- Gas pipe and liquid pipe should be heat insulated separately.
- The material for gas pipe should endure the high temperature over 120°C. That for liquid pipe should be over 70°C.
- The material thickness should be over 10mm, when ambient temp. is 30°C, and the relative humidity is over 80%, the material thickness should be over 15mm.
- The material should cling the pipe closely without gap, then be wrapped with adhesive tape. The connection wire can not be put together with the heat insulation material and should be far at least 20cm.

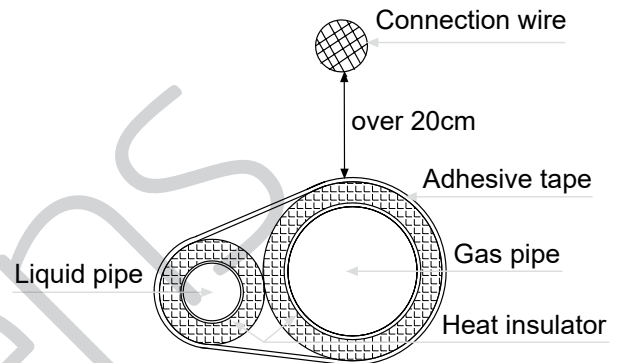

## Fix the refrigerant pipe

- In operation, the pipe will vibrate and expand or shrink. If not being fixed, the refrigerant will focus on one part to cause the broken pipe.
- To prevent the central stress, fix the pipe for every 2-3m.

## Pipe installation

When doing the piping connection, please do the following:

- Please don't let the pipe and the parts in the unit collide each other.
- When connecting the pipes, close the valves fully.
- Protect the pipe end against and water, impurities (welding after being flatted, or being sealed with adhesive tape).
- Bend the pipe as large semi-diameter as possible (over 4 times of the pipe diameter).
- The connection between outdoor liquid pipe and the distributing pipe is flared type. Please expand the pipe with the special tool for R410A after installing the expanding nut. But if the projecting pipe length has been adjusted with the copper pipe gauge, you can use the original tool to expand the pipe.
- Since the unit is with R410A, the expanding oil is ester oil, not the mineral oil.
- When doing the flare connection, please do the following: When connecting the expanding pipe, fasten the pipes with double-spanner. The torque refers to the former info.

Expanding pipe: A(mm)

Pipe outer diameter (mm)	A
Ø6.35	0 -0.4
Ø9.52	9.1
Ø12.7	13.2
Ø15.88	16.6
	19.7

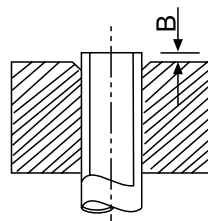

Projecting length of pipe to be expanded: B(mm)

Pipe outer diameter (mm)	When it is hard pipe	
	Special tool for R410A	The former tool
Ø6.35	0-0.5	1.0-1.5
Ø9.52		
Ø12.7		
Ø15.88		

- The outdoor gas pipe and the refrigerant distributing pipe, as well the refrigerant distributing pipe and the branch pipe should be welded with hard solder.

# Installation instruction

- Weld the pipe at the same time charge the nitrogen. Or it will cause a number of impurity (a film of oxidation) to clog the capillary and the expansion valve, further cause the deadly failure.

Seal the pipe end with adhesive tape or the stopper to increase the resistance, fill up the pipe with nitrogen.

- Protect the pipe end against the water, impurity into the pipes (welding after being flat, or being sealed with adhesive tape).

- The refrigerant pipe should be clean. The nitrogen should flow under the pressure of about 0.2MPa and when charging the nitrogen, stop up the end of the pipe by hand to enhance the pressure in the pipe, then loose the hand (meanwhile stop up the other end).

Only nitrogen gas can be used

- When connecting the pipes, close the valves fully.
- When welding the valve and the pipes, use the wet cloth to cool down the valve and the pipes.

## (6) Leakage test

- The outdoor unit has been executed the leakage test in the factory. After connecting the distributing pipe, execute the leakage test from the outdoor check valve and the indoor. Besides, while testing, the valves should be close.
- Refer to the below figure to charge the nitrogen into the unit to take a test. Never use the chlorine, oxygen, flammable gas in the leakage test. Apply pressure both on the gas pipe and the liquid pipe.
- Apply the pressure step by step to the target pressure.
  - Apply the pressure to 0.5MPa for more than 5 minutes, confirm if pressure goes down.
  - Apply the pressure to 1.5MPa for more than 5 minutes, confirm if pressure goes down.
  - Apply the pressure to the target pressure (4.0MPa), record the temp. and the pressure.
  - Leave it at 4.0MPa for over 1 day, if pressure does not go down, the test is passed. Meanwhile, when the temp. changes for 1 degree, pressure will change 0.01MPa as well. Correct the pressure.
- After confirmation of a~d, if pressure goes down, there is leakage. Check the brazing position, flared position by laying on the soap. modify the leakage point and take another leakage test.
- After leakage test, must execute the evacuation.

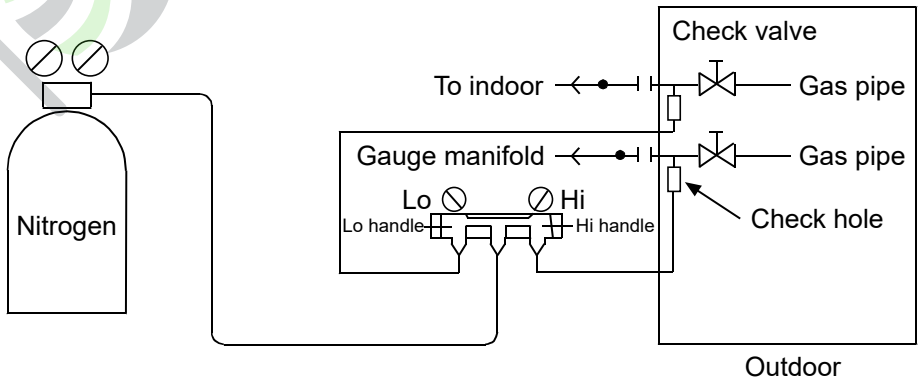

## (7) Evacuation

Evacuate at the check valve of liquid stop valve and both sides of the gas stop valve.

Operation procedure:

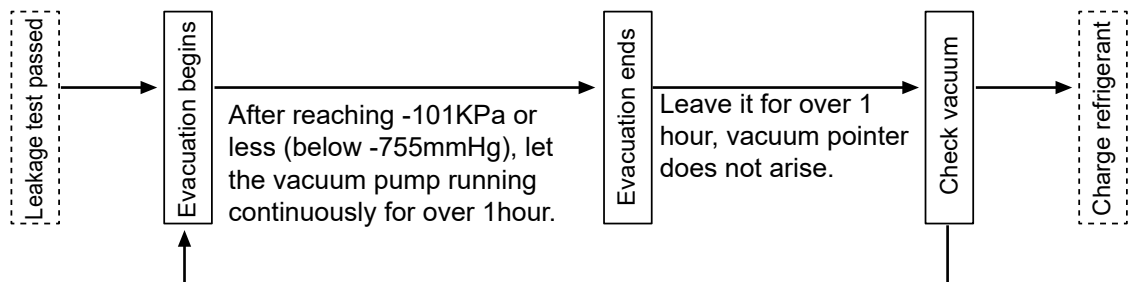

If vacuum pointer arises, it shows there is water or leakage in the system, please check and modify it, and then evacuate again.

# Installation instruction

Because the unit is with refrigerant R410A, the below issues should be paid attention:

- To prevent the different oil into the pipe, please use the special tool for R410A, especially for gauge manifold and charging hose.
- To prevent the compressor oil into the refrigerant cycle, please use the anti-counter-flow adapter.

## (8) Check valve operation

Open/close method:

- Take down the valve cap.
- Turn the liquid stop valve and the gas stop valve with hexangular spanner until it stops. If opening the valve strongly, the valve will be damaged.
- Tighten the valve cap.

Tighten torque as the table below:

Tighten torque N.m			
	Shaft (valve body)	Cap (cover)	T-shape nut (check joint)
For gas pipe	Less than 7	Less than 30	13
For liquid pipe	7.85 (MAX15.7)	29.4 (MAX39.2)	8.8 (MAX14.7)

## (9) Additional refrigerant charging

Charge the additional refrigerant as liquid state with the gauge.

If the additional refrigerant can not be charged totally when the outdoor stops, charge it at the trial mode.

If the unit runs for a long period in the state of lack of refrigerant, compressor will occur failure.

(the charging must be finished within 30 minutes especially when the unit is running, meanwhile charging the refrigerant).

A. Charging amount when out of factory excludes the refrigerant in the pipe.

B. The unit only is charged the standard volume of refrigerant (distributing pipe length is 0m). Additional charging amount=actual length of liquid pipe x additional amount per meter liquid pipe

Additional charging amount=L1×0.35+L2×0.25+L3×0.17+L4×0.11+L5×0.054+L6×0.022

L1: total length of 22.22 liquid pipe; L2: total length of 19.05 liquid pipe; L3: total length of 15.88 liquid pipe;

L4: total length of 12.7 liquid pipe; L5: total length of 9.52 liquid pipe; L6:total length of 6.35 liquid pipe;

C. Refrigerant charging and additional charging

Additional refrigerant charging per meter(kg/m)						Charge when out of factory
Ø22.22	Ø19.05	Ø15.88	Ø12.7	Ø9.52	Ø6.35	
0.35	0.25	0.17	0.11	0.054	0.022	Refer to label

Note:

- To prevent the different oil into the pipe, please use the special tool for R410A, especially for gauge manifold and charging hose.
- Mark the refrigerant type in different colour on the tank. R410A is pink.
- Must not use the charging cylinder, because the R410A will change when transferring to the cylinder.
- When charging refrigerant, the refrigerant should be taken out from the tank as liquid state.
- Mark the counted refrigerant volume due to the distributing pipe length on the label.

GWP: 2088

The product contains fluorinated greenhouse gases and its functioning relies upon such gases.

## (10) Refrigerant recovery

- Start: press the main control board of the Start and Stop keys at the same time for 5 seconds, the machine enters the refrigerant automatic recovery control: the compressor starts, the right side of the machine C0 and Ps digital tube flashing, lasted for about 3 minutes.
- Operation: when the digital tube C1 and Ps alternately flashing, manually shut off the liquid pipe valve, the refrigerant recovery.
- Off valve: when Ps < 1kg, digital tube display C2, fast manual shut-off valve, 5S after the system shut down.
- End: manual power down for program reset.

Note: heating, standby or shutdown: outdoor machine forced to refrigeration operation.

# Electric wiring and the application

## ⚠ WARNING

- Switch off the main power switch of the indoor and outdoor machine for more than 1 minutes before the wiring or regular inspection.
- To prevent the destruction of wires and electrical components by rats or other animals. Serious, it may lead to the occurrence of fire.
- To avoid damage to the wire, avoid contact with refrigerant pipes, steel edges and electrical components. Serious, it may lead to the occurrence of fire.

## ⚠ CAUTION

- Secure the power cord with a wire tie in the machine.

### Note:

when the wiring of the outdoor machine is not using the wire, it should be fixed with the rubber ring.

## ⚠ CAUTION

- In the case of 3 phase 5 wire type, the power supply of the indoor machine must be connected use L1 line and N line, prohibit the use of L1-L2, L1-L3, Otherwise the electrical part will be damaged.

## Inspect

- To ensure that the electrical equipment used on the installation site (main power switch, circuit breaker, wire, conduit and wiring terminals, etc.) have been selected according to current data, to ensure that the device in line with national standards.
- Check the power supply voltage in the range of 10% of the rated voltage and the ground wire is included in the power supply line. Otherwise, electrical parts will be damaged.
- Check whether the power supply is satisfied. Otherwise, the compressor will not start when the voltage is too low.
- By measuring the insulation resistance between the ground and the electrical device terminals, to ensure that more than 1 MΩ. Otherwise, the system can not be started until the cause of leakage and maintenance.

## Connection

- Connect the power cord to the terminal of the indoor unit and the outdoor mechanical and electrical gas box, connect the ground wire to the grounding bolt of the outdoor machine and the indoor mechanical and electrical air box.
- Connect the external and internal communication lines to the 1 and the 2 terminals on the terminal. If the power cord is connected, the printed circuit board will be damaged. And the use of shielded twisted pair wire.
- Do not connect the fastening screws on the front of the cover.
- The power cord must be made of copper wire, and the power supply must be in line with IEC 60245 requirements. If the power cord length exceeds 20m, the need to increase the size.
- The power supply line is fixed with a round connection terminal with an insulating protective sleeve. Not with sheet metal contact and extrusion, in order to avoid the cut line of skin caused by fire.

## Communication wiring figure

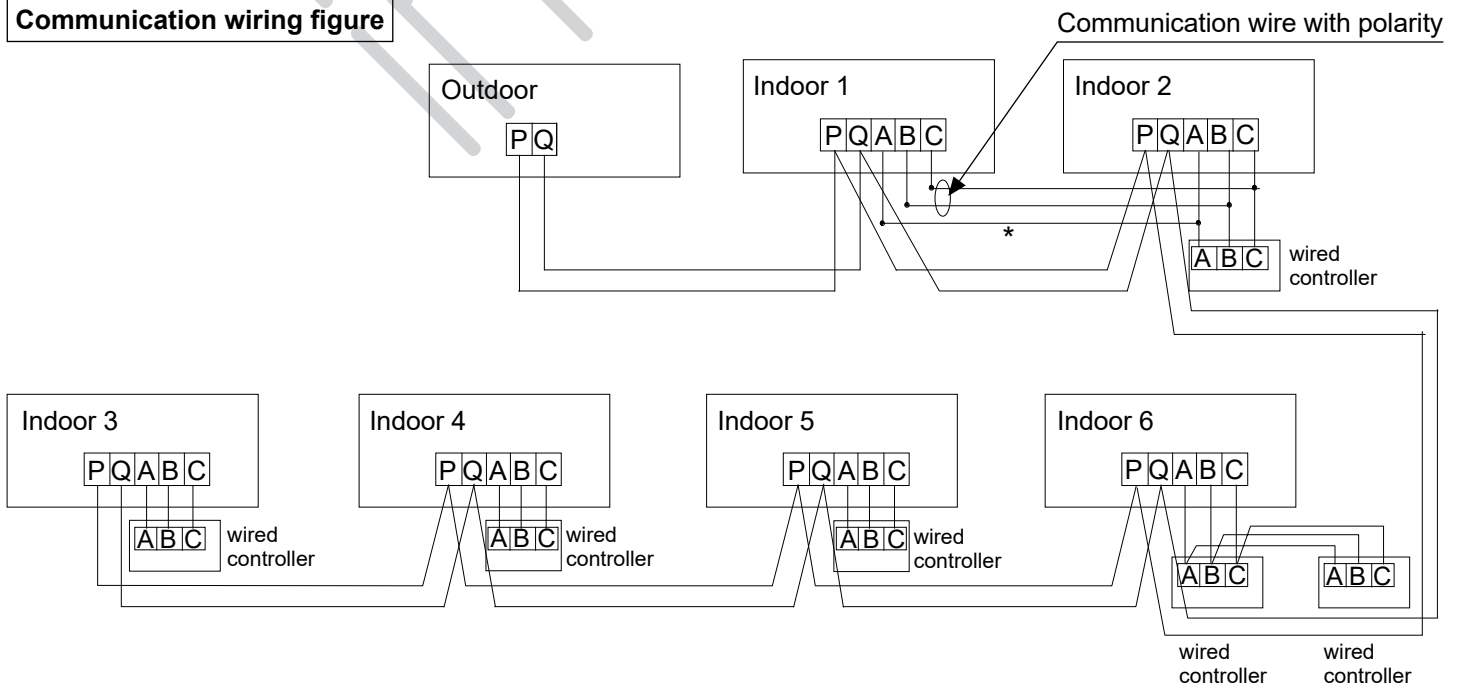



# Electric wiring and the application

The outdoor and all indoor units are in parallel through 2 non-polar wires.

Three wiring methods between wired controller and indoor unit:

A. 1 to multi (group control): one wired controller controls 2~16 indoors, as shown in above figure, indoor 1~indoor 2: indoor 2 is wired control master unit, the others are wired control slave units. Wired controller and the master indoor (directly connected to wired controller) is connected by 3 polar wires; the other indoors and the master indoors are connected by 2 or 3 polar wires, AC indoors wired "B" "C" polar wires, DC indoors wired "A" "B" "C" polar wires\*.

B. 1 to 1 (one wired controller controls one indoor): as shown in above figure, indoor 3~ indoor 4, indoor and wired controller are connected by 3 polar wires.

C. 2 to 1 (two wired controller controls one indoor): as shown in above figure, indoor 6. Either of wired controllers can be set as master wired controller, and the other is slave wired controller. Master/slave wired controller, and master/indoor are connected by 3 polar wires.

When indoor is controlled by remote controller, refer to the "wired control master unit/wired control slave unit/remote control unit table". A, B, C on signal terminal block need not wires and not connect the wired controller.

## Power wiring figure

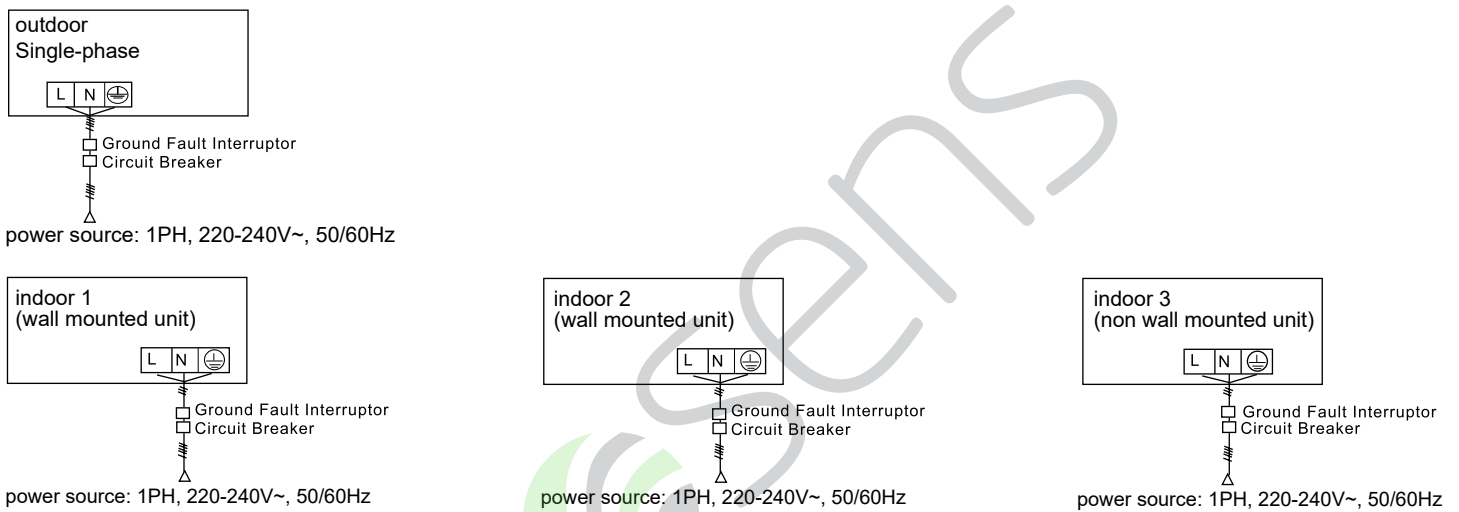

Indoor and outdoor use their individual power source. All indoors use one power source. Must install the leakage breaker and the over current breaker, or electric shock will occur.

## Outdoor power source and power cable

Item		Power source	Power cable section (mm <sup>2</sup> )	Circuit breaker (A)	Rated current of residual circuit breaker (A) Ground fault interruptor (mA) response time (S)	Ground wire	
						Section (mm <sup>2</sup> )	Screw
Individual power	AU032FSEUA	1PH, 220-240V~, 50/60Hz	4	20	20A 30mA below 0.1S	4	M5
	AU052FPEUA		10	40		10	M5
	AU072FPEUA		10	40		10	M5

- Power cable must be fixed firmly.
- To avoid electrical shock, make sure to disconnect the power supply 1 minute or more before servicing the electrical parts. Even after 1 minute, always measure the voltage at the terminals of main circuit capacitors or electrical parts and before touching, make sure that those voltages are 50VDC or less.
- To persons in charge of electrical wiring work: Do not operate the unit until the refrigerant piping is complete. (Running it before the piping is ready will break the compressor)
- Each outdoor must be earthed well.

# Electric wiring and the application

- When power cable exceeds the range, thicken it appropriately.
- The appliance shall be installed in accordance with national wiring regulations.
- All wiring must be performed by an authorized electrician.
- Be sure to install an earth leakage circuit breaker in accordance with applicable legislation. Failure to do so may cause electrical shock.

## Indoor power source and communication wiring

### ⊘ PROHIBIT

- Power lines shall not use other wires other than copper wire.
- All internal and external machines must be connected to the ground of the power supply. The earthing wire shall not be connected to the ground wire of the gas pipe, water pipe, lightning rod or telephone. If the grounding is not appropriate, may cause electric shock or fire.
- Power supply must be installed leakage circuit breaker, otherwise, may cause electric shock or fire.
- The operation and maintenance of electrical equipment shall be carried out under the condition that the power supply is cut off.
- The indoor and outdoor units set their own independent power supply.
- The signal line and the power line must be independent, non electric signal line access.

Item Indoor total current (A)	Power cable section (mm <sup>2</sup> )	Wire length (m)	Rated current of overcurrent breaker (A)	Rated current of residual circuit breaker(A) Ground fault interruptor(mA) response time(S)	Communication wire section	
					Outdoor/indoor (mm <sup>2</sup> )	Indoor/indoor (mm <sup>2</sup> )
<10	2	23	20	20A, 30mA, below 0.1s	2-core × (0.75-2.0mm <sup>2</sup> ) shielded wire	
≥10 and <15	3.5	24	30	30A, 30mA, below 0.1s		
≥15 and <22	5.5	27	40	40A, 30mA, below 0.1s		
≥22 and <27	10	42	50	50A, 30mA, below 0.1s		

- Power cable and communication wire must be fixed firmly.
- Each indoor must be grounded well.
- When power cable exceeds the range, increase the gauge appropriately.
- Shielded layer of communication wires must be connected together and be earthed at single point.
- The total length of communication wire cannot exceed 1000m.

## Communication wire for wired controller

Length of Signal Line (m)	Wiring Dimensions
≤250	0.75mm <sup>2</sup> × 3 core shielding line

- The shielding lay of the signal line must be grounded at one end.
- The total length of the signal line shall not be more than 250m.

# Electric wiring and the application

## Outdoor unit electrical wiring diagram

Outdoor unit with single fan electrical wiring diagram

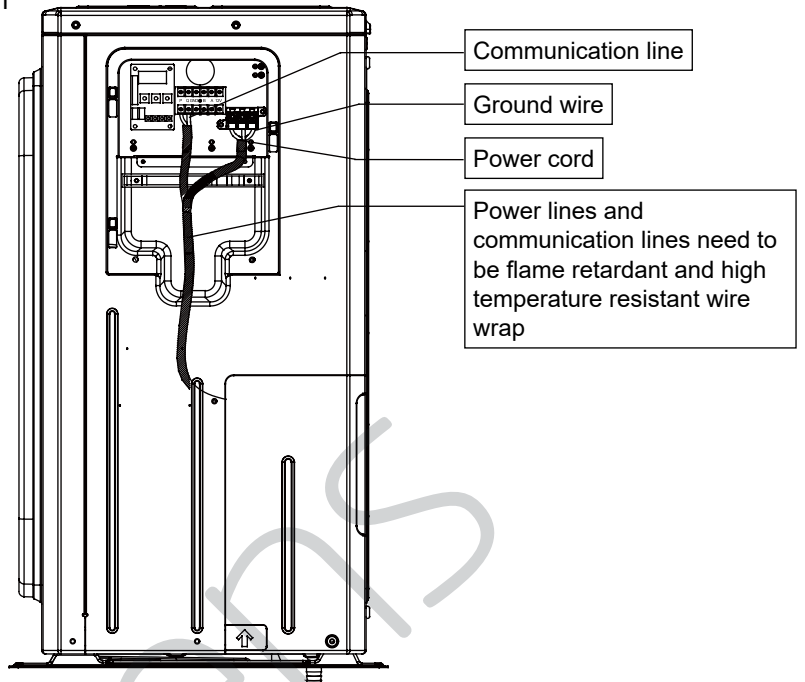

Outdoor unit with double fan electrical wiring diagram

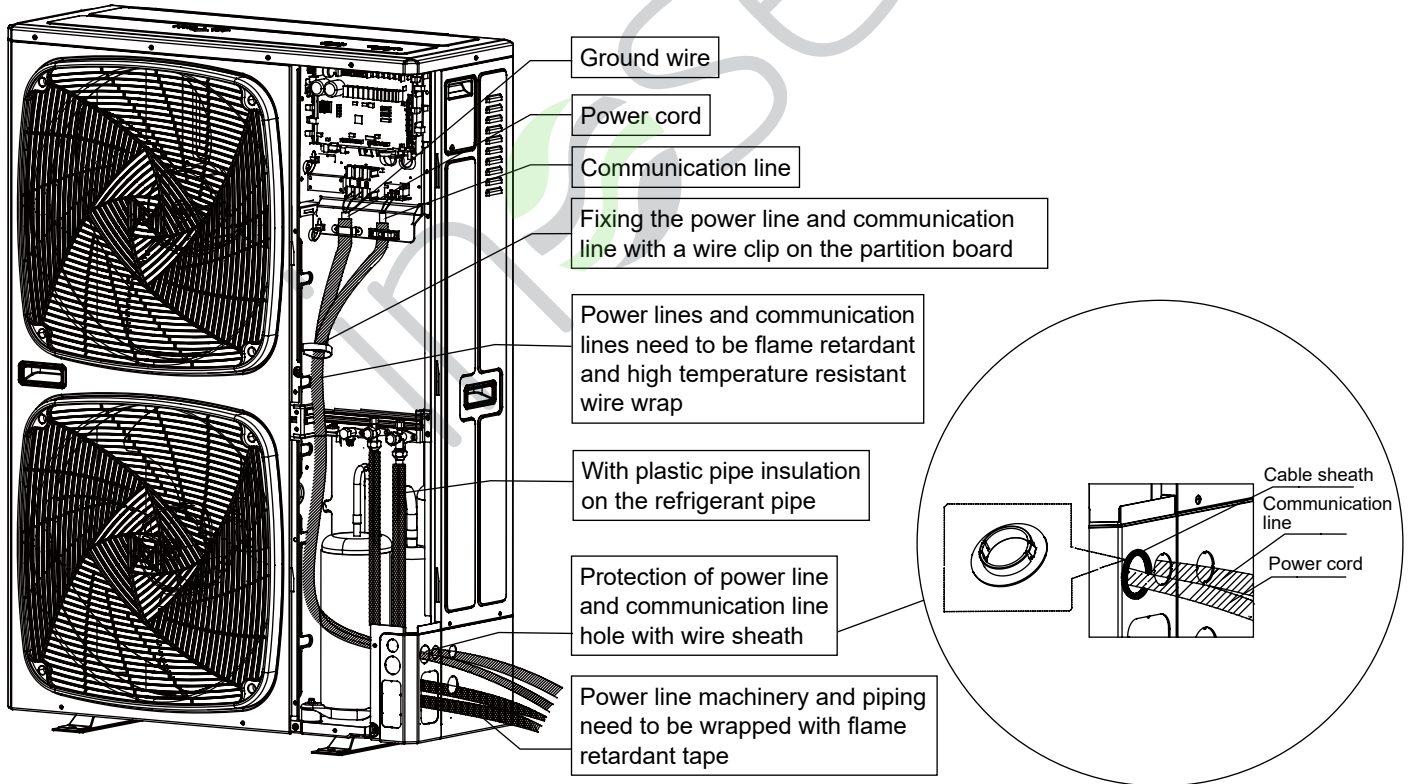

Correct

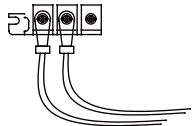

Error

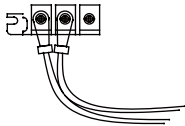

When using a single terminal without terminal, the terminal can not be directly used without flux. Otherwise, it will cause abnormal heating of terminal crimping part. If a single core wiring is used in the wiring, it can be connected directly in the manner shown in the diagram.

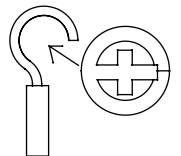

# Installation and debugging

---

## Outdoor unit PCB dipswitch setting, attention the different PCB version.

In the following table, 1 is ON, 0 is OFF.

### BM1 introduction

BM1_1	Indoor searching after startup	0	Begin to search indoor
		1	Stop searching indoor and lock the quantity

Note:

Either indoor unit unlocked or the locked quantity different with actual connecting number, it cannot run.



# Failure code

## Inverter outdoor unit failure code

Digital tube indication on master unit	Indication on wired controller (hex)	Failure code definition	Failure description	Remarks
20	20-0	Defrosting temp. sensor Te failure	AD value is below 11(open circuit) or over 1012(short circuit) for 60seconds, in cooling mode, if the sensor is abnormal, the unit does not deal with it, besides, in defrosting and within 3 minutes after defrosting, no alarm	Resumable
20-1	20-1	Defrosting temp. sensor Tc failure		
21	21	Ambient temp. sensor Ta failure	AD value is below 11(open circuit) or over 1012(short circuit) for 60seconds, in defrosting and within 3 minutes after defrosting, no alarm	Resumable
22	22	Suction temp. sensor Ts failure	AD value is below 11(open circuit) or over 1012(short circuit) for 60seconds, in defrosting and within 3 minutes after defrosting, no alarm	Resumable
23	23	Discharging temp. sensor Td failure	After compressor is running for 5 minutes, AD value is below 11(open circuit) or over 1012(short circuit) for 60seconds, in course of startup, defrosting and within 3 minutes after defrosting, no alarm	Resumable
26	26-0	Indoor communication failure	For continuous 200 cycles, can not find connected indoors	Resumable
26-1	26-1		For continuous 300seconds, the searched indoor quantity is less than the set quantity.	
26-2	26-2		For continuous 300seconds, the searched indoor quantity is more than the set quantity.	
28	28	High pressure sensor Pd failure	AD value is below 11(open circuit) or over 1012(short circuit) for 30seconds, in defrosting and within 3 minutes after defrosting, no alarm	Resumable
29	29	Low pressure sensor Ps failure	AD value is below 11(open circuit) or over 1012(short circuit) for 30seconds, in defrosting and within 3 minutes after defrosting, no alarm	Resumable
30	30	High pressure switch HPS failure	If disconnect for 50ms continuously, alarm. If alarm 3 times in an hour, confirm the failure	Once confirmation, un-resumable
33	33	EEPROM failure	EEPROM failure	Once confirmation, un-resumable
34	34	Discharging temp. too high protection (Td)	Td $\geq$ 239°F(115°C) at interval of 25msec for twice continuously, and over the set value, then stop and alarm; 3 minutes later, resume automatically. If it occurs 3 times in an hour, confirm the failure.	Once confirmation, un-resumable
35	35	4-way valve reversing failure	After 4-way valve is electrified for 3 minutes, if the below conditions can be met for continuous 10 seconds, that is conversing successfully: 1. this outdoor compressor is running normally 2. Pd-Ps $\geq$ 87PSI(0.6MPa), Otherwise, the system alarms reversing failure.	Once confirmation, un-resumable
43	43	Discharging temp. sensor Td too low protection	In normal operation, if Td<CT+50°F (10°C) for continuous 5 minutes, the unit stops and alarms.2 minutes and 50 seconds later, resume automatically. If it occurs 3 times in an hour, confirm the failure. After fixed frequency compressor alarms, inverter compressor will continue to run. If fixed frequency compressor has been locked for 3 times, the unit will stop and alarm.	Once confirmation, un-resumable

# Failure code

Digital tube indication on master unit	Indication on wired controller (hex)	Failure code definition	Failure description	Remarks
46	46	Communication with inverter board failure	No communication within 30 seconds continuously	Resumable
49	49	"Low pressure switch LPS failure"	If disconnect for 50ms continuously,alarm.If alarm 3 times in an hour,confirm the failure	"Once confirmation, un-resumable"
51-0	51-0	LEV <sub>a</sub> current is too high	LEV driver chip detection	Resumable
51-2	51-2	LEV <sub>b</sub> current is too high	LEV driver chip detection	Resumable
52-0	52-0	LEV <sub>a</sub> broken line fault	LEV driver chip detection	Resumable
52-2	52-2	LEV <sub>b</sub> broken line fault	LEV driver chip detection	Resumable
53	53	CT current is too low or current sensor fault	3 minutes after recovery	3 times in an hour, confirm failure; once confirmation, un-resumable
58	58	Tc1 temp sensor of valve plate error(sending by valve plate)	Tc1 temp. sensor cannot connect with valve plate module	Resumable
59	59	Tc2 temp sensor of valve plate error(sending by valve plate)	Tc2 temp. sensor cannot connect with valve plate module	Resumable
64	64	CT current is too high	CT current exceeds specified value, 3 minutes after recovery	3 times in an hour, confirm failure; once confirmation, un-resumable
71-0	71-0	Upper DC motor blocked	Running at speed below 20rpm for 30s, or at speed of 70% lower than the target for 2 minutes, 2 minutes and 50 seconds later after stop, resume automatically. It occurs 3 times in an hour, confirm the failure.	Once confirmation, un-resumable
71-1	71-1	Lower DC motor blocked		
81	81	IPM modular temp. too high protection	IPM modular temp.≥185°F(85°C)	3 times in an hour, confirm failure; once confirmation, un-resumable
82	82	Compressor current protection	Compressor current exceeds specified value, 3 minutes after recovery	
83	83	Outdoor model set error	Model and the number of fans do not match	Un-resumable

# Failure code

Digital tube indication on master unit	Indication on wired controller (hex)	Failure code definition	Failure description	Remarks
110	110	IPM modular protection (F0)	IPM modular over current, in short circuit, over heat, voltage too low of control circuit.	3 times in an hour, confirm failure; once confirmation, un-resumable
111	111	Compressor out of control	In the course of compressor startup or running, the unit can not detect the rotor position, or not connecting compressor.	
112	112	Radiator of transducer temp. too high	Radiator temp. too high	
114	114	Voltage too low of DC bus line of transducer	Voltage of power source is too low	
116	116	Communication abnormal between transducer and control PCB	Communication is disconnected	Resumable
117	117	Transducer over current (software)	Compressor startup fails for 5 times continuously, or compressor is running down till stops caused by over current or over heat	3 times in an hour, confirm failure; once confirmation, un-resumable
118	118	Compressor startup failure	The sensor used for current detecting of transducer is abnormal, disconnected or incorrectly connection	
119	119	Detecting circuit of transducer current is abnormal	Current detection sensor of frequency controller is abnormal or unconnected or connected wrongly.	
121	121	Power supply of inverter board is abnormal	Power supply of inverter board is broken down instantly	3 times in an hour, confirm failure; once confirmation, un-resumable
122	122	Radiator temp. sensor of transducer abnormal	Resistor of temp.sensor abnormal or temp.sensor disconnected	

When there is no failure, if the starting condition can not be met, digital tube on master unit will display stand-by code:

555.0	Standby state of capacity overmatch	When the ratio of indoor horse power and outdoor horse power is less than 50% or more than 130%, the system is in standby mode.	Resumable
555.1	Outdoor ambient temperature too high (heating)	Ta>27°C, Standby	
555.3	Outdoor ambient temperature too high or too low (cooling)	Ta>54°C or Ta<-20°C, Standby	
555.b	The running mode of outdoor unit does not match with the indoor units.	The outdoor unit maybe setted to cooling only or heating only.	

# Trial operation and the performance

## Confirm the type of outdoor machine and the number of inside machine

- After installation, please confirm that the outdoor computer board BM1\_1 is in the 0 state, and then to the unit power, observe the digital display. If the number of the indoor machine and the outdoor machine type, the power supply voltage is correct, then the BM1\_1 dial to 1 of the state, if it is not correct, please check the dial machine communication code and models, do not force the BM1\_1 dial to 1 of the state, it may cause failure of the system.

## 5-minute delay function

- If starting up the unit after being powered off, the compressor will run about 5 minutes later against being damaged.

## Cooling/heating operation

- Indoor units can be controlled individually, but cannot run in cool and heat mode at the same time. If the cool mode and the heat mode are existing simultaneously, the unit set latter will be standby, and the unit set earlier will run normally. If the A/C manager sets the unit at cooling or heating mode fixedly, the unit can not run at the other modes.

## Heating mode characteristic

- In operation if outdoor temp. arises, indoor fan motor will turn to low speed or stop.

## Defrosting in heating mode

- In heating mode, outdoor defrosting will affect the heating efficiency. The unit will defrost for about 2~10 minutes automatically, at this time, the condensate will flow from outdoor, also in defrosting, the vapour will appear at outdoor, which is normal. Indoor motor will run at low speed or stop, and outdoor motor will stop.

## The unit operation condition

- To use the unit properly, please operate the unit under the allowed condition range. If operating beyond the range, the protection device will act.
- The relative humidity should be lower than 80%. If the unit runs at the humidity over 80% for a long period, the dew on the unit will drop down and the vapour will be blown from air outlet.

## Protection device (such as high pressure switch)

- High pressure switch is the device which can stop the unit automatically when the unit runs abnormally. When the high pressure switch acts, the cooling/heating mode will stop but the running LED on wired controller will be light still. The wired controller will display failure code.  
When the following cases occur, the protection device will act:  
In cooling mode, air outlet and air inlet of outdoor are clogged.  
In heating mode, indoor filter is stucked with duct; indoor air outlet is clogged.  
When protection device acts, please cut off the power source and re-start up after eliminating the trouble.

## When power failure

- When power is failure in running, all the operations will stop.
- After being electrified again, if with re-satrt up function, the unit can resume to the state before power off automatically; if without re-satrt up function, the unit needs to be switched on again.
- When abnormal occurs in running because of the thunder, the lightning, the interference of car or radio, etc, please cut off the power source, after eliminating the failure, press "ON/OFF" button to start up the unit.

## Heating capacity

- The heating mode adopts the heat pump type that absorbs outdoor heat energy and releases into indoor. So if outdoor temperature goes down, the heating capacity will decrease.

## System marks

- On the condition that multi Outdoor systems are installed, in order to confirm the relationship between outdoor and indoor, please make marks on outdoor electric control box cover to indicate the connected indoor unit. As the below figure:

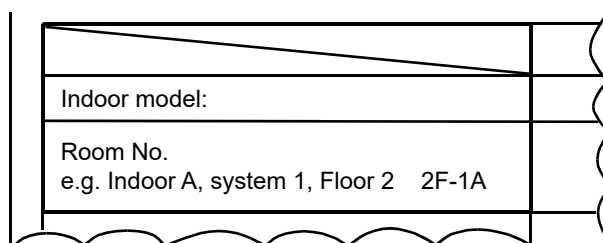



# Trial operation and the performance

---

## Trial operation

- Before trial operation:

Before being electrified, measure the resistor between power terminal block (live wire and neutral wire) and the earthed point with a multimeter, and check if it is over 1MΩ. If not, the unit can not operate.

To protect compressor, electrify the outdoor unit for at least 12 hours before the unit runs. If the crankcase heater is not electrified for 6 hours, the compressor will not work.

Confirm the compressor bottom getting hot.

Except for the condition that there is only one master unit connected (no slave unit), under the other conditions, open fully the outdoor operating valves (gas side, liquid side). If operating the unit without opening the valves, compressor failure will occur.

Confirm all indoor units being electrified. If not, water leakage will occur.

Measure the system pressure with pressure gauge, at the same time, operate the unit.

- Trial operation

In trial operation, refer to the information of performance section. When the unit can not start up at the room temperature, make trial operation for outdoor.



# Move and scrap the air conditioning

---

- When moving, to disassemble and re-install the air conditioning, please contact your dealer for technical support.
- In the composition material of air conditioning, the content of lead, mercury, hexavalent chromium, polybrominated biphenyls and polybrominated diphenyl ethers are not more than 0.1% (mass fraction) and cadmium is not more than 0.01% (mass fraction).
- Please recycle the refrigerant before scrapping, moving, setting and repairing the air conditioning; for the air conditioning scrapping, should be dealt with by the qualified enterprises.



inSens



Qingdao Haier Air Conditioner Electric Co.,Ltd.

Haier Industrial Park,Qianwangang Road,Eco-Tech Development Zone,Qingdao 266555,  
Shandong,P.R.C.