



User's Manual

Split Air Conditioner

MODEL

TPW-12

TPW-18

Content

Operation Notices	
Precautions	1
Parts Name	4
Operation Guide	
Operation guide.....	5
Remote controller	6
Buttons on remote controller.....	7
Maintenance	
Clean and Maintenance	14
Malfunction	
Malfunction analysis.....	16
Installation Notice	
Installation drawing	19
Installation prepare	20
Installation	
Installation of indoor unit.....	22
Installation of outdoor unit.....	26
Check after installation	30
Test operation.....	30
Attachment	
Configuration of connection pipe.....	31
Pipe expanding method.....	32



This marking indicates that this product should not be disposed with other household wastes throughout the EU. To prevent possible harm to the environment or human health from un-controlled waste disposal, recycle it responsibly to promote the sustainable reuse of material resources. To return your used device, please use the return and collection systems or contact the retailer where the product was purchased. They can take this product for environmental safe recycling.

Precautions

Operation and Maintenance

This appliance can be used by children aged of 8 years and above and persons with reduced physical, sensory or mental capabilities or lack of experience and knowledge if they have been given supervision or instruction concerning use of the appliance in a safe way and understand the hazards involved.

Children shall not play with the appliance.

Cleaning and user maintenance shall not be made by children without supervision.

Do not connect air conditioner to multi-purpose socket. Otherwise, it may cause fire hazard.

Do disconnect power supply when cleaning air conditioner. Otherwise, it may cause electric shock.

If the supply cord is damaged, it must be replaced by the manufacturer, its service agent or similarly qualified persons in order to avoid a hazard.

Do not wash the air conditioner with water to avoid electric shock.

Do not spray water on indoor unit. It may cause electric shock or malfunction.

After removing the filter, do not touch fins to avoid injury.

Do not use fire or hair dryer to dry the filter to avoid deformation or fire hazard.



WARNING

Maintenance must be performed by qualified professionals. Otherwise, it may cause personal injury or damage.

Do not repair air conditioner by yourself. It may cause electric shock or damage. Please contact dealer when you need to repair air conditioner.

Do not extend fingers or objects into air inlet or air outlet. It may cause personal injury or damage.

Do not block air outlet or air inlet. It may cause malfunction.

Do not spill water on the remote controller, otherwise the remote controller may be broken.

When below phenomenon occurs, please turn off air conditioner and disconnect power immediately, and then contact the dealer or qualified professionals for service.

- Power cord is overheating or damaged.
- There's abnormal sound during operation.
- Circuit break trips off frequently.
- Air conditioner gives off burning smell.
- Indoor unit is leaking.

If the air conditioner operates under abnormal conditions, it may cause malfunction, electric shock or fire hazard.

When turning on or turning off the unit by emergency operation switch, please press this switch with an insulating object other than metal.

Do not step on top panel of outdoor unit, or put heavy objects. It may cause damage or personal injury.

Precautions

Attachment

Installation must be performed by qualified professionals. Otherwise, it may cause personal injury or damage.

Must follow the electric safety regulations when installing the unit.

According to the local safety regulations, use qualified power supply circuit and circuit break.

Do not install the circuit break. If not, it may cause malfunction.

An all-pole disconnection switch having a contact separation of at least 3mm in all poles should be connected in fixed wiring.

Including an circuit break with suitable capacity, please note the following table. Air switch should be included magnet buckle and heating buckle function, it can protect the circuit-short and overload.

Air Conditioner should be properly grounded. Incorrect grounding may cause electric shock.

Don't use unqualified power cord.

Make sure the power supply matches with the requirement of air conditioner. Unstable power supply or incorrect wiring or malfunction. Please install proper power supply cables before using the air conditioner.

Properly connect the live wire, neutral wire and grounding wire of power socket.

Be sure to cut off the power supply before proceeding any work related to electricity and safety.

Do not put through the power before finishing installation.

If the supply cord is damaged, it must be replaced by the manufacturer, its service agent or similarly qualified persons in order to avoid a hazard.



WARNING

The temperature of refrigerant circuit will be high, please keep the interconnection cable away from the copper tube.

The appliance shall be installed in accordance with national wiring regulations.

Installation must be performed in accordance with the requirement of NEC and CEC by authorized personnel only.

The air conditioner is the first class electric appliance. It must be properly grounding with specialized grounding device by a professional. Please make sure it is always grounded effectively, otherwise it may cause electric shock.

The yellow-green wire in air conditioner is grounding wire, which can't be used for other purposes.

The grounding resistance should comply with national electric safety regulations.

The appliance must be positioned so that the plug is accessible.

All wires of indoor unit and outdoor unit should be connected by a professional.

If the length of power connection wire is insufficient, please contact the supplier for a new one. Avoid extending the wire by yourself.

For the air conditioner with plug, the plug should be reachable after finishing installation.

For the air conditioner without plug, an circuit break must be installed in the line.

If you need to relocate the air conditioner to another place, only the qualified person can perform the work. Otherwise, it may cause personal injury or damage.

Select a location which is out of reach for children and far away from animals or plants. If it is unavoidable, please add the fence for safety purpose.

The indoor unit should be installed close to the wall.

Precautions

Working temperature range

	Indoor side DB/WB(C)	Outdoor side DB/WB(C)
Maximum cooling	32/23	43/26
Maximum heating	27/-	24/18

The operating temperature range (outdoor temperature) for cooling only unit is 18 C ~ 43 C ,
for heat pump unit is -7 C ~ 43 C .

Parts Name

Indoor unit

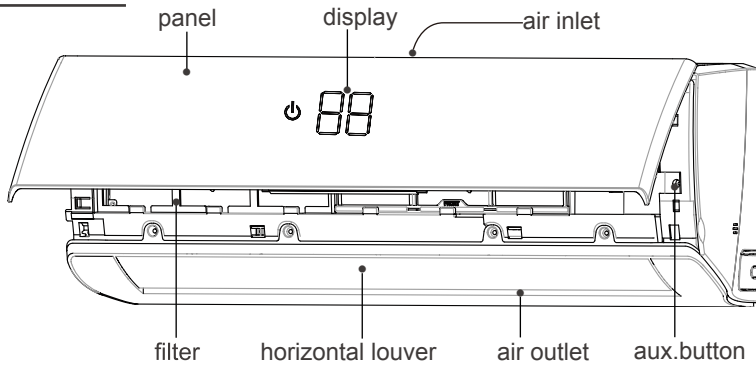

remote controller

Outdoor unit

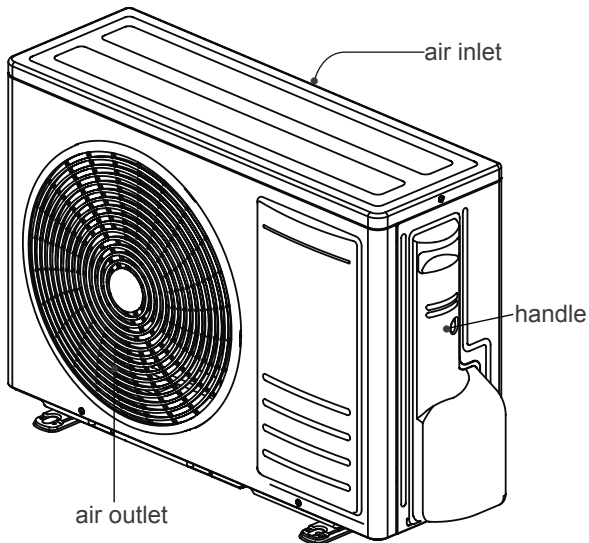

Operation guide

Installation batteries

1. Press the back side of remote controller marked with "☰", as shown in the fig, and then push out the cover of battery box along the arrow direction.

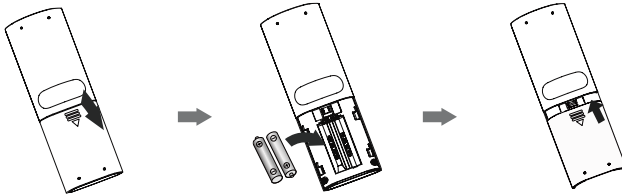

2. Installation two 7# (AAA 1.5V) dry batteries, and make sure the position of "+" polar and "-" polar are correct.
3. Reinstall the cover of battery box.

Operation guide

1. After connecting the power, press "⏻" button on remote controller to turn on the air conditioner.
2. Press "MODE" button to select your required mode: Auto, Cool, Dry, Fan, Heat.
3. Press "(-)" or "(+)" button to set your required temperature. (Temperature can't be adjusted under auto mode).
4. Press "FAN" button to set your required fan speed: auto, fan1, fan2, fan3, fan4, fan5, infinite speed.
5. Press "↺" or "↻" button to select fan blowing angle.

NOTE:

- During operation, point the remote control signal sender at the receiving window on indoor unit.
- The distance between signal sender and receiving window should be no more than 8m, and there should be no obstacles between them.
- Signal may be interfered easily in the room where there is fluorescent lamp or wireless telephone; remote controller should be close to indoor unit during operation.
- Replace new batteries of the same model when replacement is required.
- When you don't use remote controller for a long time, please take out the batteries.
- If the display on remote controller is fuzzy or there's no display, please replace batteries.

Remote controller

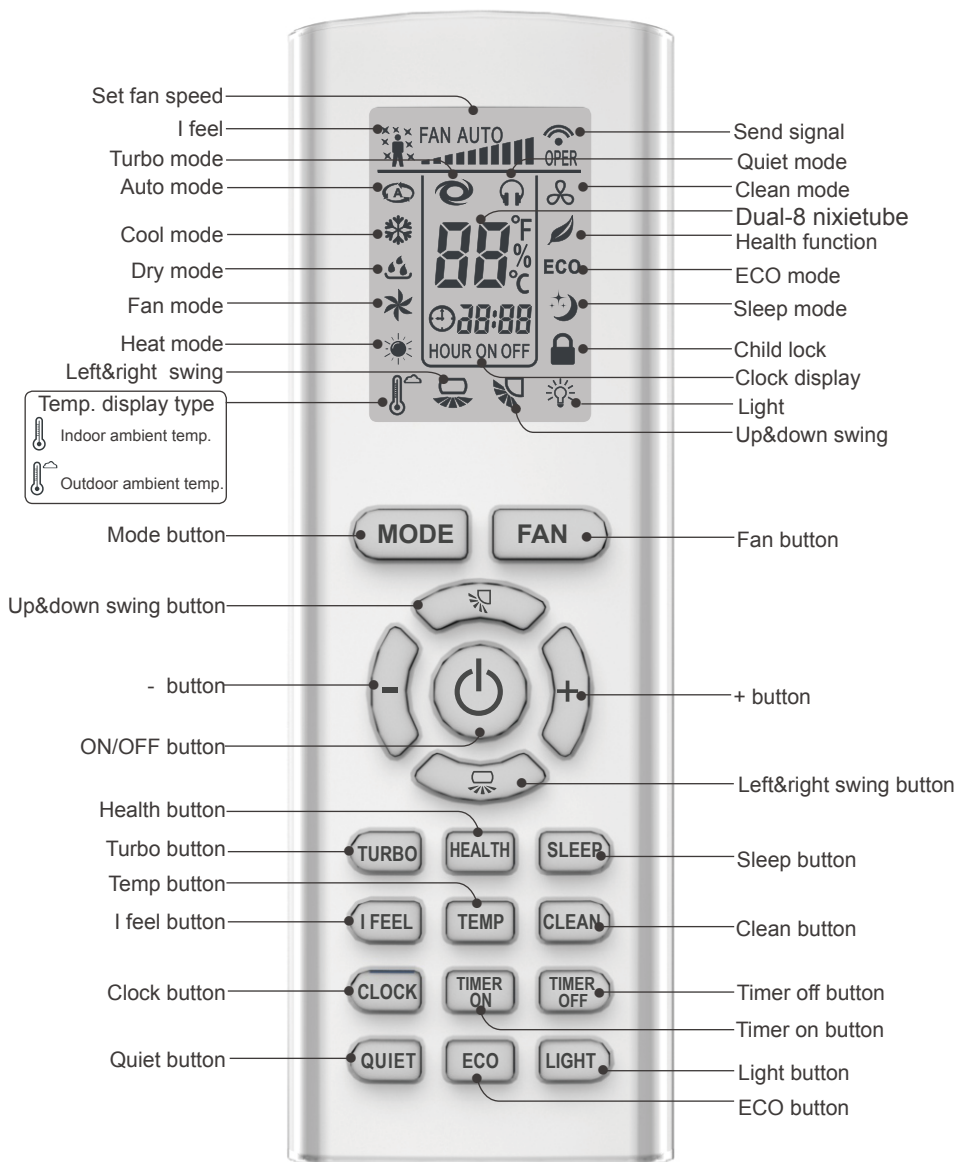

Buttons on remote controller

After connecting the power, the air conditioner will make a sound.

Power indicator is ON. After that, you can operate the air conditioner by using remote controller.

Under on status, pressing the button on the remote controller, the signal icon "📶" on the display of remote controller will blink once and the air conditioner will give out a "de" sound, which means the signal has been sent to the air conditioner. The display will show the corresponding set function icons.

Under off status, light and clock icon will be displayed on the display of remote controller (If timer on, timer off and light functions are set, the corresponding icons will be displayed on the display of remote controller at the same time).

ON/OFF button

Press this button can turn on or turn off the air conditioner.

MODE button

Press this button to select your required operation mode.



- When selecting auto mode, air conditioner will operate automatically according to ex-factory setting. Set temperature can't be adjusted and will not be displayed as well. Press "FAN" button can adjust fan speed. Press "↖" or "↗" button can adjust fan blowing angle.
- After selecting cool mode, air conditioner will operate under cool mode. Press "+" or "-" button to adjust set temperature. Press "FAN" button to adjust fan speed. Press "↖" or "↗" button to adjust fan blowing angle.
- When selecting dry mode, the air conditioner operates at fan1, fan speed can't be adjusted. Press "↖" or "↗" button to adjust fan blowing angle.
- When selecting fan mode, the air conditioner will only blow fan, no cooling and no heating. Press "FAN" button to adjust fan speed. Press "↖" or "↗" button to adjust fan blowing angle.
- When selecting heat mode, the air conditioner operates under heat mode. Press "+" or "-" button to adjust set temperature. Press "FAN" button to adjust fan speed. Press "↖" or "↗" button to adjust fan blowing angle. (Cooling only unit won't receive heat mode signal. If setting heat mode with remote controller, press "ON/OFF" button can't start up the unit).

Note:

- For preventing cold air, after starting up heating mode, indoor unit will delay 1~5 minutes to blow air (actual delay time is depend on indoor ambient temperature).
- Set temperature range from remote controller: 16~31°C;
Fan speed: auto, fan1, fan2, fan3, fan4, fan5, stepless speed.

Buttons on remote controller

FAN button

Pressing this button can set fan speed circularly as: auto (AUTO), fan1 (), fan2 (), fan3 (), fan4 (), fan5 (), stepless speed.

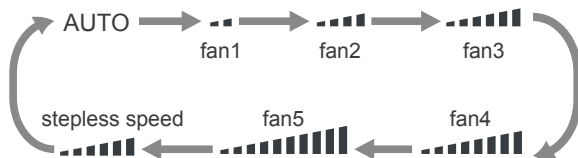

Note:

- In AUTO speed, air conditioner will select proper fan speed automatically according to ambient temperature.
- Fan speed under dry mode is fan1.
- After entering the stepless speed mode, users can adjust the fan speed according to the button "+" or "-".

button

- Press this button the up&down swing function can be started and canceled. The remote controller defaults to static swing condition.
- Press "MODE" button and " " button at the same time when remote controller OFF to switch between simple swing and static swing.
- In static swing condition, pressing this button, the swing angle of up&down swing louver changes as below:

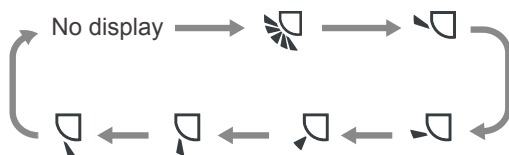

Note:







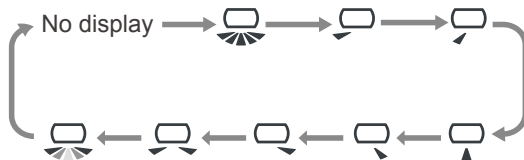

- When selecting " " with remote controller, it's auto swing. up&down swing louver of air conditioner will swing up&down automatically at the maximum angle.
- When selecting " " with remote controller, it's the fixed position swing. Up&down swing louver of air conditioner will stop at that position as shown by the icon to swing.

button

- Press this button the left&right swing function can be started and canceled. The remote controller defaults to static swing condition.
- Press "MODE" button and " " button at the same time at remote controller OFF to switch between simple swing and static swing.
- In static swing condition, pressing this button, the swing angle of left&right swing louver changes as below:

Buttons on remote controller



- When selecting "  " with remote controller, it's auto swing. left&right swing louver of air conditioner will swing left&right automatically at the maximum angle.
- When selecting " , , , , ,  " with remote controller, it's the fixed position swing. Left&right swing louver of air conditioner will stop at that position as shown by the icon to swing.
- When selecting "  ", it's the circulating swing. Left&right swing louver of air conditioner will swing circularly according to the angle as shown by the icon.

Note:

There is no this function for the units. If press this button, the main unit will sound, but it also runs under original status.

+ and - button

Press "+" or "-" button once to increase or decrease 1°C of set temperature. Holding "+" or "-" button, set temperature on remote controller will change quickly. On releasing button after setting is finished, temperature indicator on indoor unit will change accordingly. (Temperature can't be adjusted under auto mode)

- When setting TIMER ON, TIMER OFF or CLOCK, press "+" or "-" button to adjust time (Refer to CLOCK, TIMER ON, TIMER OFF buttons).

TURBO button

Press this button to turn on or turn off the TURBO function in cool、heat、fan mode.

Note:

- Press "QUIET" or "FAN" button the unit will quit this function.
- This function is no use in auto mode or dry mode.

HEALTH button

Press this button to turn on or turn off the health function.

SLEEP button

Press this button to turn on or turn off the SLEEP function under cool、heat、dry mode.

Note:

- This function is off as defaulted after power on.
- It will be cleared after changing mode.
- It is no use under "FAN" mode and "AUTO" mode.

Buttons on remote controller

I FEEL button

Press this button to start I FEEL function and "👤" will be displayed on the remote controller. After this function is set, the remote controller will send the detected ambient temperature to the indoor unit and the unit will automatically adjust the indoor temperature according to the detected temperature. Press this button again to close I FEEL function and "👤" will disappear.

Note:

Please put the remote controller near user and confirm the unit can receive the remote code when this function is set. Do not put the remote controller near the object of high temperature or low temperature in order to avoid detecting inaccurate ambient temperature.

TEMP button

By pressing this button, you can see indoor set temperature, indoor ambient temperature or outdoor ambient temperature on indoor unit's display. The setting on remote controller is selected circularly as below:

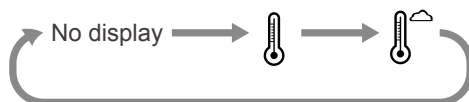

- When selecting "no display" on the remote controller, the temperature indicator which on the indoor units will display the set temperature.
- When selecting "🌡️" with remote controller, temperature indicator on indoor unit displays indoor ambient temperature.
- When selecting "🌡️☁️" with remote controller, temperature indicator on indoor unit displays outdoor ambient temperature.

Note:

Outdoor temperature display is not available for some models. At that time, indoor unit receives "🌡️" signal, it displays indoor set temperature.

CLEAN button

- Press this button to start or cancel clean function.
- It is unable to set clean function when the unit is on; if the air conditioner runs in cool or dry mode before turning off, press "CLEAN" button and show "🌀" then the clean function is on; press "CLEAN" button again, "🌀" disappeared, then the clean function is off, or running 10 mins in clean function then turn off automatically.
- In the first power on, the clean function is off acquiescently.
- The clean function can not be set and displayed when the air conditioner is in auto, fan and heat mode before turn off.

Buttons on remote controller

CLOCK button

Press this button to set clock time. "⌚" and "28:88" icon on remote controller will blink. Press "+" or "-" button within 5s to set clock time. Each pressing of "+" or "-" button, clock time will increase or decrease 1 hour. Press this button again, "⌚" and "28:88" icon on remote controller will blink. Press "+" or "-" button within 5s to set clock time. Press this button another time, "⌚" and "28:88" icon on remote controller will blink. Press "+" or "-" button within 5s to set clock time. If hold "+" or "-" button, clock time will change quickly. Release when reaching your required time. Press "CLOCK" button to confirm the time, "⌚" icon stops blinking.

Note:

- Clock time adopts 24-hour mode.
- The interval between two operation can't exceeds 5s. Otherwise, remote controller will quit setting status. Operation for TIMER ON/TIMER OFF is the same.

TIMER ON button

This button can set the time for timer on. After pressing this button, "⌚" icon disappears, "ON" and "28:88" icon on remote controller blinks. Press "+" or "-" button within 5s to set "TIMER ON" time. Each pressing of "+" or "-" button, the time will increase or decrease 1 hour. Press this button again, "ON" and "28:88" icon on remote controller will blink. Press "+" or "-" button within 5s to set the time. Press this button another time, "ON" and "28:88" icon on remote controller will blink. Press "+" or "-" button within 5s to set the time. Hold "+" or "-" button, the time will change quickly until reaching your required time. Press "TIMER ON" to confirm it. The word "ON" will stop blinking. "⌚" icon resumes displaying.

Cancel TIMER ON

Under the condition that TIMER ON is started up, press "TIMER ON" button to cancel it.

TIMER OFF button

This button can set the time for timer off. After pressing this button, "⌚" icon disappears, "OFF" and "28:88" icon on remote controller blink. Press "+" or "-" button within 5s to set "TIMER OFF" time. Each pressing of "+" or "-" button, the time will increase or decrease 1 hour. Press this button again, "OFF" and "28:88" icon on remote controller will blink. Press "+" or "-" button within 5s to set the time. Press this button another time, "OFF" and "28:88" icon on remote controller will blink. Press "+" or "-" button within 5s to set the time. Hold "+" or "-" button, the time will change quickly until reaching your required time. Press "TIMER OFF" to confirm it. The word "OFF" will stop blinking. "⌚" icon resumes displaying.

Cancel TIMER OFF

Under the condition that TIMER OFF is started up, press "TIMER OFF" button to cancel it.

Buttons on remote controller

QUIET button

Press this button to turn on or turn off the QUIET function in cool、heat、auto mode.

Note:

- Press "TURBO" or "FAN" button the unit will quit this function.
- This function is no use in fan mode or dry mode.

ECO button

In cool mode, press "ECO" button and the unit will operate under ECO mode.

Note:

- Remote controller displays "**ECO**".
- Air conditioner will operate at auto speed. Set temperature can't be adjusted.
- Under cool mode, sleep function can not work with ECO mode together at the same time.
- Change mode will exit the ECO mode.

LIGHT button

Press this button can turn off the light for indoor unit's display. "💡" icon on remote controller will disappear. Press this button again to turn on the light for indoor unit's display. "💡" icon on remote controller will be displayed.

Function introduction for combination buttons

Child lock function

Press "+" and "-" simultaneously to turn on or turn off child lock function. When child lock function is on, "🔒" icon is displayed on remote controller. If you operate the remote controller, the "🔒" icon will blink three times without sending signal to the unit.

Temperature display switchover function

In the off mode, press "-" and "MODE" buttons simultaneously to switch temperature display between °C and °F.

Timing defrost

In the heating mode, press "SLEEP" and "TURBO" buttons together for 3s would start or cancel the Timing defrost.

Buttons on remote controller

The minimum cooling temperature setting

In the off mode, pressing "TEMP" and "-" button at the same time, the LCD will display the minimum cooling temperature. The default temperature is 16°C and you can adjust the temperature with "+" or "-" from 16°C to 31°C, 3 seconds later it will return to the standby mode.

The maximum heating temperature setting

In the off mode, pressing "TEMP" and "+" button at the same time, the LCD will display the maximum heating temperature. The default temperature is 31°C and you can modulate the temperature with "+" or "-" from 16°C to 31°C, 3 seconds later it will return to the standby mode.

Low temperature heating function setting

- In heating mode, pressing "Mode" and "+" button at the same time will enter/exit the low temperature heating function.
- "LA" would be showed on the remote controller after entered into the low temperature heating function.
- When switching from one mode to another mode, low temperature heating function was canceled. Turn off and then turn on air conditioner that will remain the low temperature heating function. After powered on, the low temperature heating mode was default to off status.
- In the low temperature heating mode, "Sleep" and "Low temperature heating" function cannot start at same time. When low temperature heating mode has already started, meanwhile you press the "SLEEP" button, the air conditioner will exit low temperature heating mode and enter the sleep mode. Vice versa.

Note:

1. In the low temperature heating mode, the fan speed was default to Auto and non-adjustable.
2. In the low temperature heating mode, "Turbo" and "Quiet" can't be set. If enter the low temperature heating mode, the turbo and quiet function that started before will be canceled. As well as when exit the low temperature heating mode, it will not resume.
3. When exit from the low temperature heating mode, the speed and temperature will turn into the original condition before it started.
4. You can set up other function.

Clean and Maintenance

WARNING

- Turn off the air conditioner and disconnect the power before cleaning the air conditioner to avoid electric shock.
- Do not wash the air conditioner with water to avoid electric shock.
- Do not use volatile liquid to clean the air conditioner.

Clean surface of indoor unit

When the surface of indoor unit is dirty, it is recommended to use a soft dry cloth or wet cloth to wipe it.

Note:

Do not remove the panel when cleaning it.

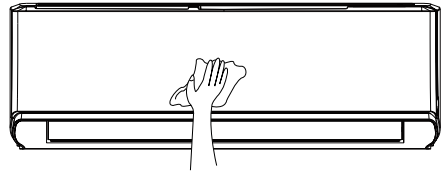

Clean filter

1 Open panel

Pull out the panel to a certain angle as shown in the fig.

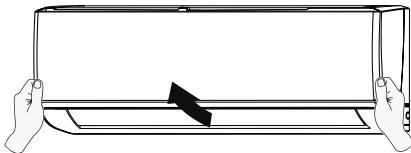

2 Remove filter

Remove the filter as indicated in the fig.



3 Clean filter

Use dust catcher or water to clean the filter. when the filter is very dirty, use the water (below 45 C) to clean it, and then put it in a shady and cool place to dry.

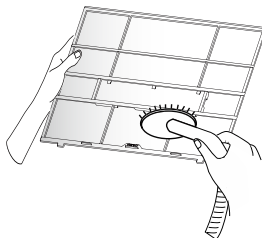

4 Installation filter

Installtion the filter and then close the panel cover tightly.

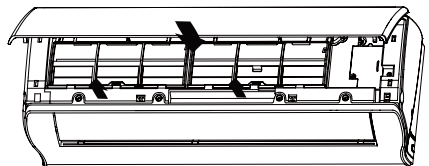

Clean and Maintenance

NOTE:

The filter should be cleaned every three months. If there is much dust in the operation environment, clean frequency can be increased.

After removing the filter, do not touch fins to avoid injury.

Do not use fire or hair dryer to dry the filter to avoid deformation or fire hazard.

Checking before use-season

1. Check whether air inlets and air outlets are blocked.
2. Check whether air switch, plug and socket are in good condition.
3. Check whether filter is clean.
4. Check whether drainage pipe is damaged.

Checking after use-season

1. Disconnect power supply.
2. Clean filter and indoor unit's panel .

Notice for recovery

1. Most of packing materials are recyclable materials.
Please dispose them in appropriate recycling unit.
2. If you want to dispose the air conditioner, please contact local dealer or consultant service center for the correct disposal method.

Malfunction analysis

General phenomenon analysis

Please check below items before asking for maintenance. If the malfunction still can't be eliminated, please contact local dealer or qualified professionals.

Phenomenon	Check items	Solution
Indoor unit can't receive remote controller's signal or remote controller has no action.	Whether it's interfered severely (such as static electricity, stable voltage)?	Pull out the plug. Reinsert the plug after about 3min, and then turn on the unit again.
	Whether remote controller is within the signal receiving range?	Signal receiving range is 8m.
	Whether there are obstacles?	Remove obstacles.
	Whether remote controller is pointing at the receiving window?	Select proper angle and point the remote controller at the receiving window on indoor unit
	Is sensitivity of remote controller low; fuzzy display and no display?	Check the batteries. If the power of batteries is too low, please replace them.
	No display when operating remote controller?	Check whether remote controller appears to be damaged. If yes, replace it.
	Fluorescent lamp in room?	Take the remote controller close to indoor unit. Turn off the fluorescent lamp and then try it again.
No air emitted from indoor unit.	Air inlet or air outlet of indoor unit is blocked?	Eliminate obstacles.
	Under heating mode, indoor temperature is reached to set temperature?	After reaching to set temperature, indoor unit will stop blowing out air.
	Heating mode is turned on just now?	In order to prevent blowing out cold air, indoor unit will be started after delaying for several minutes, which is a normal phenomenon.
Air conditioner can't operate	Power failure?	Wait until power recovery.
	Is plug loose?	Reinsert the plug.
	Circuit break trips off or fuse is burnt out?	Ask professional to replace circuit break or fuse.
	Wiring has malfunction?	Ask professional to replace it
	Unit has restarted immediately after stopping operation?	Wait for 3min, and then turn on the unit again.
	Whether the function setting for remote controller is correct?	Reset the function.

Malfunction analysis

Mist is emitted from indoor unit's air outlet.	Indoor temperature and humidity is high?	Because indoor air is cooled rapidly. After a while, indoor temperature and humidity will be decrease and mist will disappear.
Set temperature can't be adjusted	Unit is operating under auto mode?	Temperature can't be adjusted under auto mode. Please switch the operation mode if you need to adjust temperature.
	Your required temperature exceeds the set temperature range?	Set temperature range: 16°C ~31°C
Cooling (heating) effect is not good.	Voltage is too low?	Wait until the voltage resumes normal.
	Filter is dirty?	Clean the filter.
	Set temperature is in proper range?	Adjust temperature to proper range.
Door and window are open?	Door and window are open?	Close door and window.
	Odours are emitted	Whether there's odour source, such as furniture and cigarette, etc. Clean the filter. Eliminate the odour source.
Air conditioner operates normally suddenly	Whether there's interference, such as thunder, wireless devices, etc.	Disconnect power, put back power, and then turn on the unit again.
Outdoor unit has vapor	Heating mode is turned on?	During defrosting under heating mode, it may generate vapor, which is a normal phenomenon.
"Water flowing" noise	Air conditioner is turned on or turned off just now?	The noise is the sound of refrigerant flowing inside the unit, which is a normal phenomenon.
Cracking noise	Air conditioner is turned on or turned off just now?	This is the sound of friction caused by expansion and/or contraction of panel or other parts due to the change of temperature.

Malfunction analysis

Error Code

When air conditioner status is abnormal, temperature indicator on indoor unit will blink to display corresponding error code. Please refer to below list for identification of error code.



Note:

Above indicator diagram is only for reference. Please refer to actual product for the actual indicator and position.

Below listed error codes are only part error codes. Please refer to error code list in service manual for more information.

Error code	Troubleshooting	Solution
E1	Overheat protection	Turn off, restart after 5min, if the code occurs again after a few minutes, please contact the professional person.
E2	Over current protection	Turn off, restart after 5min, if the code occurs again after a few minutes, please contact the professional person.
HE	Auxiliary heater drive circuit malfunction	Pull out the plug, please contact the professional person.
L0	Jumper malfunction	Pull out the plug, restart after 10s, if the code occurs again, please contact the professional person.
L1	PG motor(indoor)zero-crossing detecting circuit malfunction	Turn off, restart after a few seconds, if the code occurs again after a few minutes, please contact the professional person.
L2	No feedback signal of indoor unit fan	Turn off, restart after a few seconds, if the code occurs again after a few minutes, please contact the professional person.
U0	Short/open circuit of indoor environment sensor	Power off the unit, restart after 10s, if the code occurs again, please contact the professional person.
U1	Short/open circuit of indoor unit tube sensor	Power off the unit, restart after 10s, if the code occurs again, please contact the professional person.
b3	Filter filth blockage alert	Power off, clean filter. If the filter is not dirty, turn off the air conditioner for 2s then restart, the code will be removed automatically.

If there're other error codes, please contact qualified professionals for service.

Contact us

When below phenomenon occurs, please turn off air conditioner and disconnect power immediately, and then contact the dealer or qualified professionals for service.

- Power cord is overheating or damaged.
- Air conditioner gives off burning smell.
- There's abnormal sound during operation.
- Circuit break trips off frequently.
- Indoor unit is leaking.

Do not repair or refit the air conditioner by yourself.

If the air conditioner operates under abnormal conditions, it may cause malfunction, electric shock or fire hazard.

Installation drawing

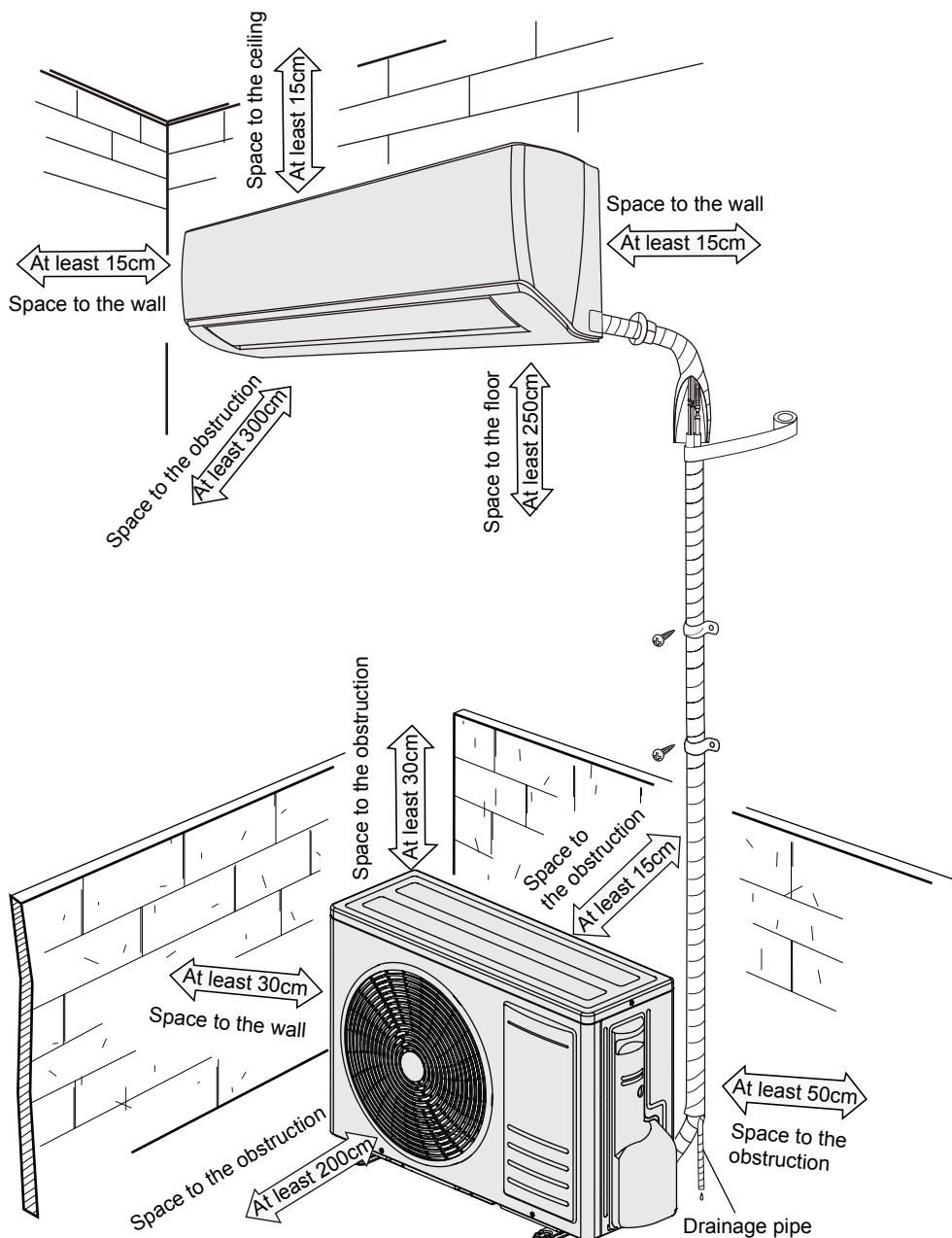

Installation prepare

Tools

1 Level meter	2 Screw driver	3 Impact drill
4 Drill head	5 Pipe expander	6 Torque wrench
7 Open-end wrench	8 Pipe cutter	9 Leakage detector
10 Vacuum pump	11 Pressure meter	12 Universal meter
13 Inner hexagon spanner	14 Measuring tape	

Selection of location

Basic requirement

Installing the unit in the following places may cause malfunction. If it is unavoidable, please consult the local dealer:

1. The place with strong heat sources, vapors, flammable or explosive gas, or volatile objects spread in the air.
2. The place with high-frequency devices (such as welding machine, medical equipment).
3. The place near coast area.
4. The place with oil or fumes in the air.
5. The place with sulfureted gas.
6. Other places with special circumstances.
7. The appliance shall not be installed in the laundry.

Indoor unit

1. There should be no obstruction near air inlet and air outlet.
2. Select a location where the condensation water can be dispersed easily and won't affect other people.
3. Select a location which is convenient to connect the outdoor unit and near the power socket.
4. Select a location which is out of reach for children.
5. The location should be able to withstand the weight of indoor unit and won't increase noise and vibration.
6. The appliance must be installed 2.5m above floor.
7. Don't install the indoor unit right above the electric appliance.
8. Please try your best to keep way from fluorescent lamp.

Outdoor unit

1. Select a location where the noise and out flow air emitted by the outdoor unit will not affect neighborhood.
2. The location should be well ventilated and dry, in which the outdoor unit won't be exposed directly to sunlight or strong wind.
3. The location should be able to withstand the weight of outdoor unit.
4. Make sure that the installation follows the requirement of installation dimension diagram.
5. Select a location which is out of reach for children and far away from animals or plants. If it is unavoidable, please add the fence for safety purpose.

Installation prepare

Safety precaution

1. Must follow the electric safety regulations when installing the unit.
2. According to the local safety regulations, use qualified power supply circuit and circuit break.
3. Make sure the power supply matches with the requirement of air conditioner. Unstable power supply or incorrect wiring or malfunction. Please install proper power supply cables before using the air conditioner.
4. Properly connect the live wire, neutral wire and grounding wire of power socket.
5. Be sure to cut off the power supply before proceeding any work related to electricity and safety.
6. Do not connect the power before finishing inatallation.
7. If the supply cord is damaged, it must be replaced by the manufacturer, its service agent or similarly qualified persons in order to avoid a hazard.
8. The temperature of refrigerant circuit will be high, please keep the interconnection cable away from the copper tube.
9. The appliance shall be installed in accordance with national wiring regulations.
10. Installation must be performed in accordance with the requirement of NEC and CEC by authorized personnel only.

Grounding requirement

1. The air conditioner is the first class electric appliance. It must be properly grounding with specialized grounding device by a professional. Please make sure it is always grounded effectively, otherwise it may cause electric shock.
2. The yellow-green wire in air conditioner is grounding wire, which can't be used for other purposes.
3. The grounding resistance should comply with national electric safety regulations.
4. The appliance must be positioned so that the plug is accessible.
5. An all-pole disconnection switch having a contact separation of at least 3mm in all poles should be connected in fixed wiring. For models with a power plug, make sure the plug is within reach after installation.
6. Including an circuit break with suitable capacity, please note the following table. Circuit break should be included magnet buckle and heating buckle function, it can protect the circuit-short and overload. (Caution: please do not use the fuse only for protect the circuit)

Air-conditioner(Cooling capacity)	Circuit break capacity
12000Btu/h	16A
18000Btu/h	25A

Installation of indoor unit

Step 1: Choosing installation location

Recommend the installation location to the client and then confirm it with the client.

Step 2: Install wall-mounting frame

1. Hang the wall-mounting frame on the wall; adjust it in horizontal position with the level meter and then point out the screw fixing holes on the wall .
2. Drill the screw fixing holes on the wall with impact drill (the specification of drill head should be the same as the plastic expansion particle) and then fill the plastic expansion particles in the holes.
3. Fix the wall-mounting frame on the wall with tapping screws (ST4.2X25TA) and then check if the frame is firmly installed by pulling the frame. If the plastic expansion particle is loose, please drill another fixing hole nearby.

Step 3: Open piping hole

1. Choose the position of piping hole according to the direction of outlet pipe. The position of piping hole should be a little lower than the wall-mounted frame, shown as below.

Cooling Capacity: 12000Btu/h

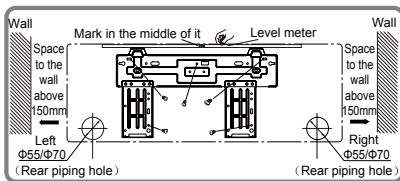

Cooling Capacity: 18000Btu/h

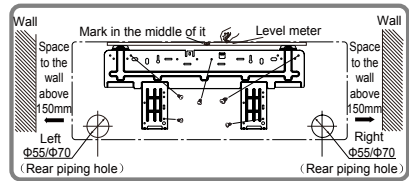

2. Open a piping hole with the diameter of $\Phi 55/\Phi 70$ on the selected outlet pipe position. In order to drain smoothly, slant the piping hole on the wall slightly downward to the outdoor side with the gradient of $5-10^\circ$.

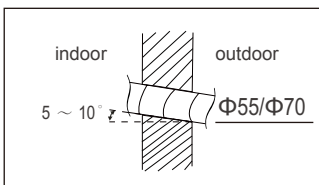

Note:

- Pay attention to dust prevention and take relevant safety measures when opening the hole.
- The plastic expansion particles are not provided and should be bought locally.

Installation of indoor unit

Step 4: Outlet pipe

1. The pipe can be led out in the direction of right, rear right or left.

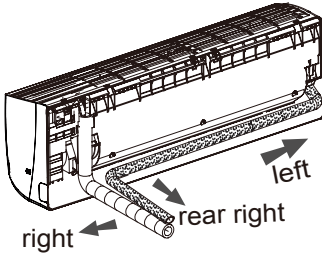

2. When select leading out the pipe from left or right, please cut off the hole on the bottom case.

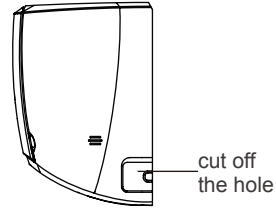

Step 5: Connect the pipe of indoor unit

1. Aim the pipe joint at the corresponding bellmouth.

2. Pretightening the union nut with hand.

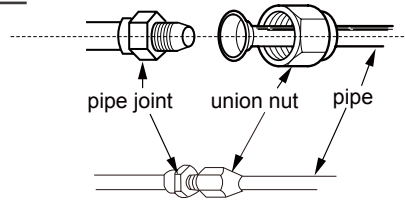

3. Adjust the torque force by referring to the following sheet. Place the open-end wrench on the pipe joint and place the torque wrench on the union nut. Tighten the union nut with torque wrench.

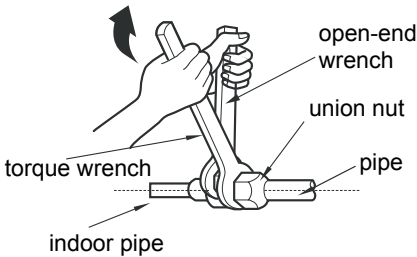

Hex nut diameter	Tightening torque (N.m)
Φ 6	15-20
Φ 9.52	30~40
Φ 12	45~55
Φ 16	60~65
Φ 19	70~75

4. Wrap the indoor pipe and joint of connection pipe with insulating pipe, and then wrap it with tape.

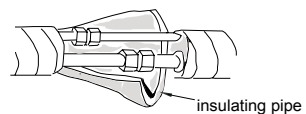

Installation of indoor unit

Step 6: Install drain hose

1. Connect the drain hose to the outlet pipe of indoor unit.
2. Bind the joint with tape.

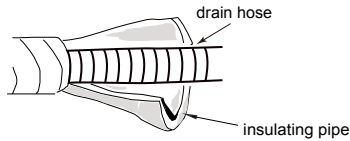
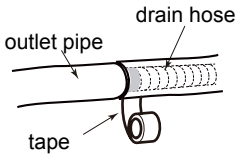
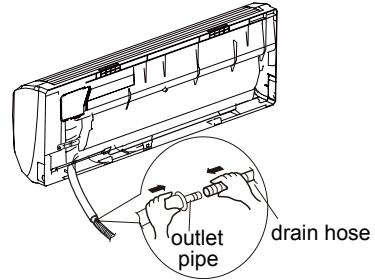

- Add insulating pipe in the indoor drain hose in order to prevent condensation.
- The plastic expansion particles are not provided.

Step 7: Connect wire of indoor unit

1. Open the panel, remove the screw on the wiring cover and then take down the cover.

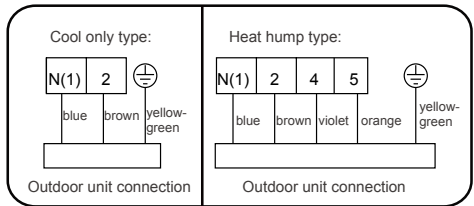
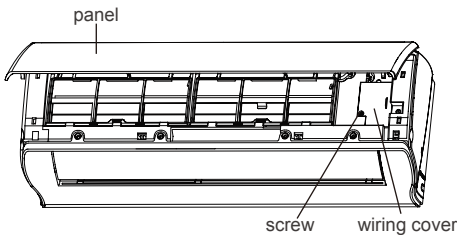

2. Make the power connection wire go through the cable-cross hole at the back of indoor unit and then pull it out from the front side.
3. Remove the wire clip, connect the power connection wire to the wiring terminal according to the color; tighten the screw and then fix the power connection wire with wire clip.
4. Put wiring cover back and then tighten the screw.
5. Close the panel.

Note:

- All wires of indoor unit and outdoor unit should be connected by a professional.
- If the length of power connection wire is insufficient, please contact the supplier for a new one. Avoid extending the wire by yourself.
- For the air conditioner with plug, the plug should be reachable after finishing installation.
- For the air conditioner without plug, an air switch must be installed in the line. The air switch should be all-pole parting and the contact parting distance should be more than 3mm.

Installation of indoor unit

Step 8: Bind up pipe

1. Bind up the connection pipe, power cord and drain hose with the band.
2. Reserve a certain length of drain hose and power cord for installation when binding them. When binding to a certain degree, separate the indoor power and then separate the drain hose.

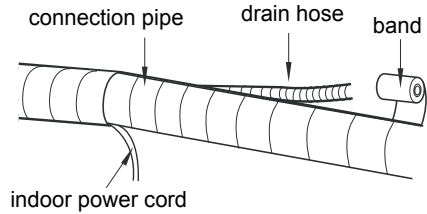
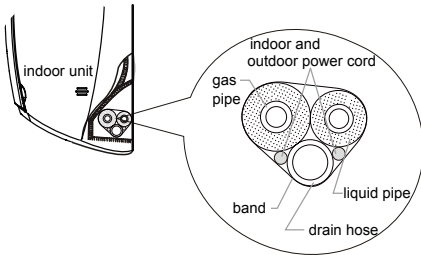

3. Bind them evenly.
4. The liquid pipe and gas pipe should be bound separately at the end.

Note:

- The power cord and control wire can't be crossed or winding.
- The drain hose should be bound at the bottom.

Step 9: Hang the indoor unit

1. Put the bound pipes in the wall pipe and then make them pass through the wall hole.
2. Hang the indoor unit on the wall-mounting frame.
3. Stuff the gap between pipes and wall hole with sealing gum.
4. Fix the wall pipe.
5. Check if the indoor unit is installed firmly and closed to the wall.

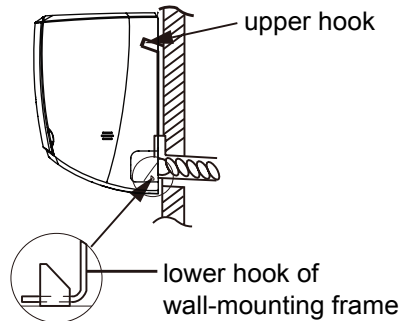
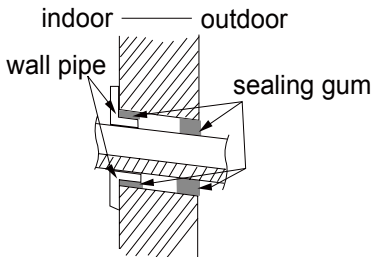

- Do not bend the drain hose too excessively in order to prevent blocking.

Installation of outdoor unit

Step 1: Fix the support of outdoor

Select it according to the actual installation situation

1. Select installation location according to the house structure.
2. Fix the support of outdoor unit on the selected location with expansion screws.

Note:

- Take sufficient protective measures when installing the outdoor unit.
- Make sure the support can withstand at least four times of the unit weight.
- The outdoor unit should be installed at least 3cm above the the floor in order to install drainjoint.
- For the unit with cooling capacity of 2300W ~5000W, 6 expansion screws are needed;
- for the unit with cooling capacity of 6000W ~8000W, 8 expansion screws are needed;
- for the unit with cooling capacity of 10000W ~16000W, 10 expansion screws are needed.

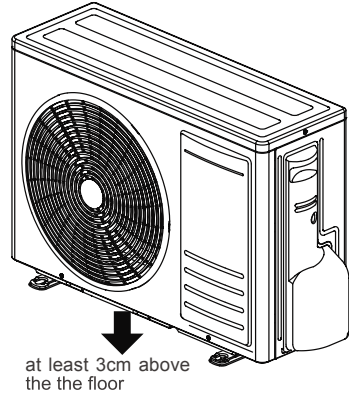

Step 2: Install drain joint

(Only for cooling and heating unit)

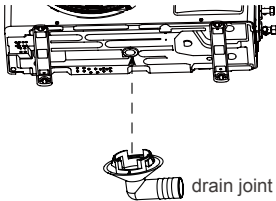

1. Connect the outdoor drain joint into the hole on the chassis, as shown in the picture below.
2. Connect the drain hose into the drain vent.

Step 3: Fix outdoor unit

1. Place the outdoor unit on the support.
2. Fix the foot holes of outdoor unit with bolts.

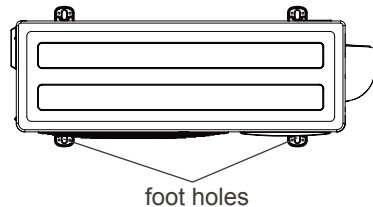

Installation of outdoor unit

Step 4: Connect indoor and outdoor pipe

1. Remove the screw on the right handle of outdoor unit and then remove the handle.
2. Remove the screw cap of valve and aim the pipe joint at the bellmouth of pipe.

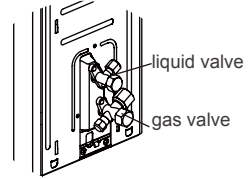
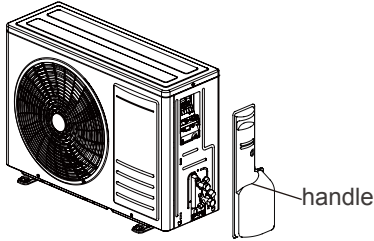

3. Pretightening the union nut with hand.

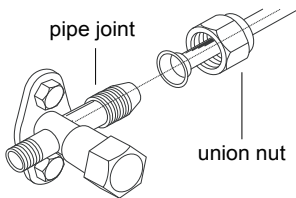

4. Tighten the union nut with torque wrench by referring to the sheet below.

Hex nut diameter	Tightening torque (N.m)
Φ 6	15-20
Φ 9.52	30~40
Φ 12	45~55
Φ 16	60~65
Φ 19	70~75

Step 5: Connect indoor and outdoor pipe

1. Remove the wire clip; connect the power connection wire and signal control wire (only for cooling and heating unit) to the wiring terminal according to the color, fix them with screws.
2. Fix the power connection wire and signal control wire with wire clip (only for cooling and heating unit).

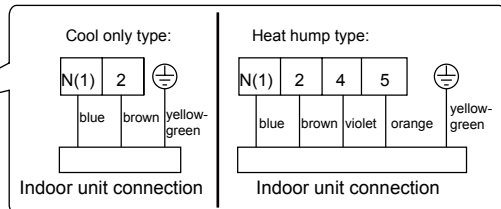
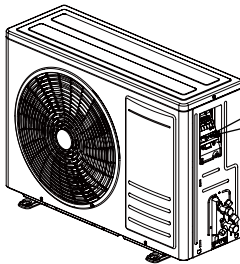

Note:

- After tighten the screw, pull the power cord slightly to check if it is firm.
- Never cut the power connection wire to prolong or shorten the distance.

Installation of outdoor unit

Step 6: Neaten the pipes

1. The pipes should be placed along the wall, bent reasonably and hidden possibly. Min. semidiameter of bending the pipe is 10cm.
2. If the outdoor unit is higher than the wall hole, you must set a U-shaped curve in the pipe before pipe goes into the room, in order to prevent rain from getting into the room.

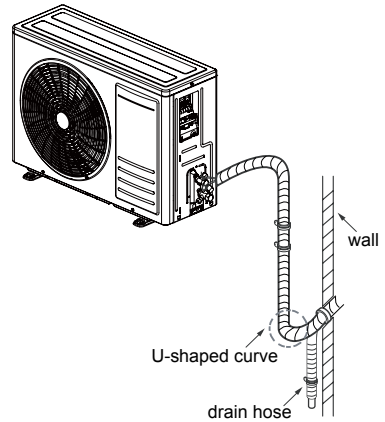

Note:

The through-wall height of drain hose shouldn't be higher than the outlet pipe hole of indoor unit.

The water outlet can't be placed in water in order to drain smoothly.

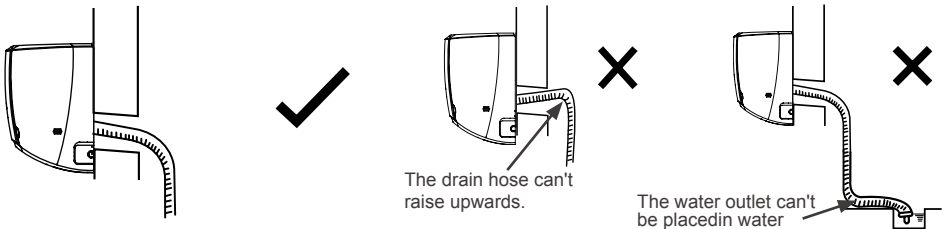

Slant the drain hose slightly downwards. The drain hose can't be curved, raised and fluctuant, etc.

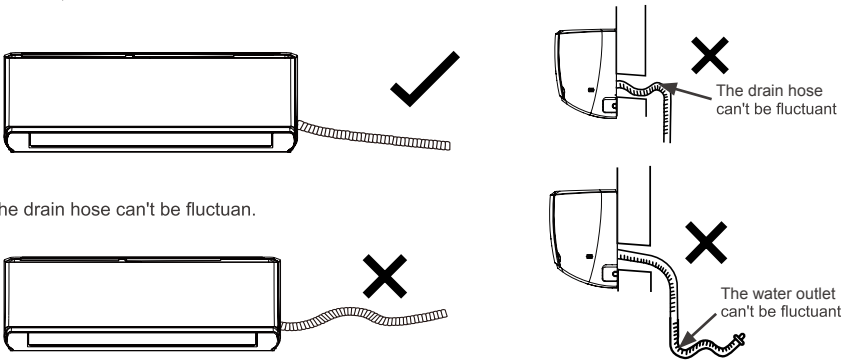

Installation of outdoor unit

Step 7: Vacuum pumping

Use vacuum pump

1. Remove the valve caps on the liquid valve and gas valve and the nut of refrigerant charging vent.
2. Connect the charging hose of piezometer to the refrigerant charging vent of gas valve and then connect the other charging hose to the vacuum pump.
3. Open the piezometer completely and operate for 10-15min to check if the pressure of piezometer remains in -0.1MPa .
4. Close the vacuum pump and maintain this status for 1-2min to check if the pressure of piezometer remains in -0.1MPa . If the pressure decreases, there may be leakage.
5. Remove the piezometer, open the valve core of liquid valve and gas valve completely with inner hexagon spanner.
6. Tighten the screw caps of valve and refrigerant charging vent.
7. Reinstall the handle.

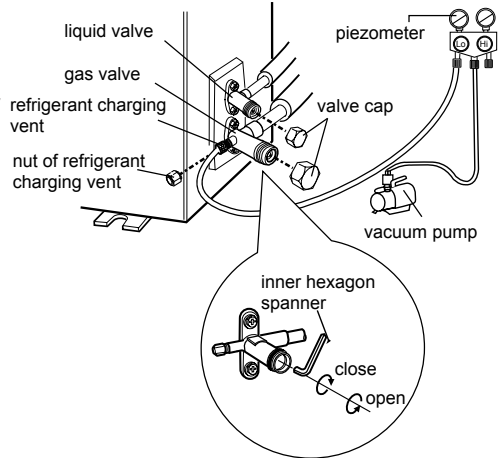

Step 8: Leakage detection

1. With leakage detector:
Check if there is leakage with leakage detector.
2. With soap water:
If leakage detector is not available, please use soap water for leakage detection.
Apply soap water at the suspected position and keep the soap water for more than 3min.
If there are air bubbles coming out of this position, there's a leakage.

Check after installation

Check according to the following requirement after finishing installation.

Items to be checked	Possible malfunction
Has the unit been installed firmly?	The unit may drop, shake or emit noise
Have you done the refrigerant leakage test?	It may cause insufficient cooling(heating) capacity.
Is heat insulation of pipeline sufficient?	It may cause condensation and water dripping.
Is water drained well?	It may cause condensation and water dripping.
Is the voltage of power supply according to the voltage marked on the nameplate?	It may cause malfunction or damaging the parts.
Is electric wiring and pipeline installed correctly?	It may cause malfunction or damaging the parts.
Is the unit grounded securely?	It may cause electric leakage.
Does the power cord follow the specification?	It may cause malfunction or damaging the parts.
Is there any obstruction in the air inlet and outlet?	It may cause insufficient cooling(heating) capacity.
The dust and sundries caused during installation are removed?	It may cause malfunction or damaging the parts.
The gas valve and liquid valve of connection pipe are open completely?	It may cause insufficient cooling(heating) capacity.

Test operation

1. Preparation of test operation

- The client approves the air conditioner.
- Specify the important notes for air conditioner to the client.

2. Method of test operation

- Connect the power, press ON/OFF button on the remote controller to start operation.
- Press MODE button to select AUTO, COOL, DRY, FAN and HEAT to check whether the operation is normal or not.
- If the ambient temperature is lower than 16℃, the air conditioner can't start cooling.

Configuration of connection pipe

- Standard length of connection pipe
 - 5m, 7.5m, 8m.
- Min. length of connection pipe is 3m.
- Max. length of connection pipe and max. high difference.

Cooling capacity	Max length of connection pipe	Max height difference	Cooling capacity	Max length of connection pipe	Max height difference
5000Btu/h (1465W)	15	5	24000Btu/h (7032W)	25	10
7000Btu/h (2051W)	15	5	28000Btu/h (8204W)	30	10
9000Btu/h (2637W)	15	5	36000Btu/h (10548W)	30	20
12000Btu/h (3516W)	20	10	42000Btu/h (12306W)	30	20
18000Btu/h (5274W)	25	10	48000Btu/h (14064W)	30	20

4. The additional refrigerant oil and refrigerant charging required after prolonging connection pipe

- After the length of connection pipe is prolonged for 10m at the basis of standard length, you should add 5ml of refrigerant oil for each additional 5m of connection pipe.
- The calculation method of additional refrigerant charging amount (on the basis of liquid pipe):

$$\text{Additional refrigerant charging amount} = \text{prolonged length of liquid pipe} \times \text{additional refrigerant charging amount per meter}$$

- Basing on the length of standard pipe, add refrigerant according to the requirement as shown in the table. The additional refrigerant charging amount per meter is different according to the diameter of liquid pipe. See the following sheet.

Additional refrigerant charging amount for R22, R407C, R410A and R134a

Diameter of connection pipe		Outdoor unit throttle	
Liquid pipe(mm)	Gas pipe(mm)	Cooling only(g/m)	Cooling and heating(g/m)
Φ6	Φ9.52 or Φ12	15	20
Φ6 or Φ9.52	Φ16 or Φ19	15	50
Φ12	Φ19 or Φ22.2	30	120
Φ16	Φ25.4 or Φ31.8	60	120
Φ19	-	250	250
Φ22.2	-	350	350

Pipe expanding method

Improper pipe expanding is the main cause of refrigerant leakage. Please expand the pipe according to the following steps:

A: Cut the pipe

Confirm the pipe length according to the distance of indoor unit and outdoor unit. Cut the required pipe with pipe cutter.

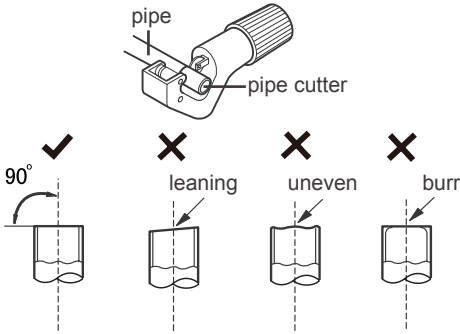

B: Remove the burrs

Remove the burrs with shaper and prevent the burrs from getting into the pipe.

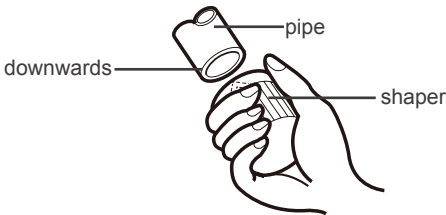

C: Put on suitable insulating pipe

D: Put on the union nut

Remove the union nut on the indoor connection pipe and outdoor valve; install the union nut on the pipe.

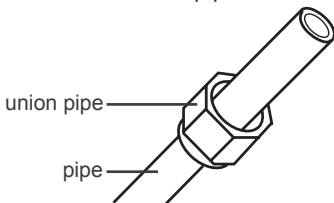

E: Expand the port

Expand the port with expander.

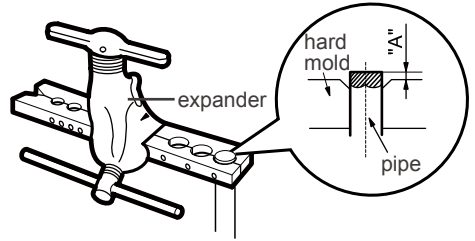

Note:

• "A" is different according to the diameter, please refer to the sheet below:

Outer diameter(mm)	A(mm)	
	Max	Min
Φ6 - 6.35(1/4")	1.3	0.7
Φ9.52(3/8")	1.6	1.0
Φ12-12.7(1/2")	1.8	1.0
Φ15.8-16(5/8")	2.4	2.2

F: Inspection

Check the quality of expanding port. If there is any blemish, expand the port again according to the steps above.

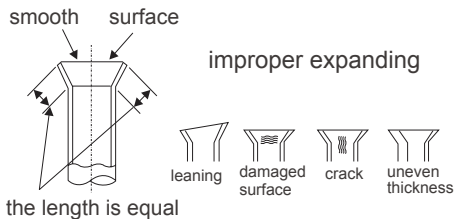



Tekno Point Italia Srl
Via dell'Artigianato 5
30020 Marcon (VE)
www.teknopoint.com

K49100000046